

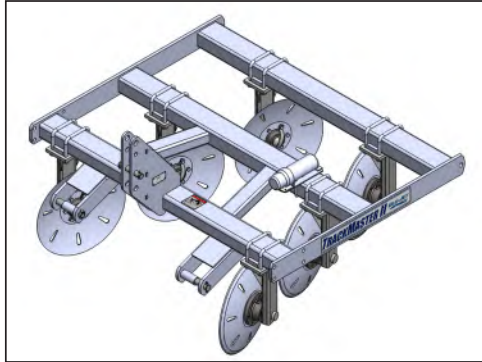

Primary
Tillage



TrackMaster II

Serial Number A66960100 & Higher

Part No. J08000010

Foreword



This symbol identifies important safety messages. When you see it, read the message that follows and be alert to the possibility of personal injury.

Remember, safety instructions stated in this manual are for your protection. Read them carefully and follow them closely when working around or using this machine.

Read and study this manual completely before attempting to operate this implement. Take this manual to the field for handy reference when operating, adjusting, or servicing your machine.

When referenced, “Right-Hand” (RH) and “Left-Hand” (LH) side of the machine are determined by standing behind the machine and facing in the direction of travel.

Pre-Delivery Checklist

- Hardware tightened
- Machine lubricated
- Safety and operating procedures reviewed
- Field adjustment information reviewed
- Warranty information reviewed

Product Information

When ordering parts or when requesting further information or assistance, always give the following information:

- Machine name
- Model number
- Serial number

All products manufactured by Unverferth Mfg. Co., Inc. are warranted to be free from material and workmanship defects for one full year from time of consumer delivery. Your local dealer will gladly assist you with any warranty questions.

Please fill out and retain this portion for your records.

Purchase Date _____ Model _____ Serial No. _____

Dealer _____ City _____

Dealer Contact _____ Phone _____

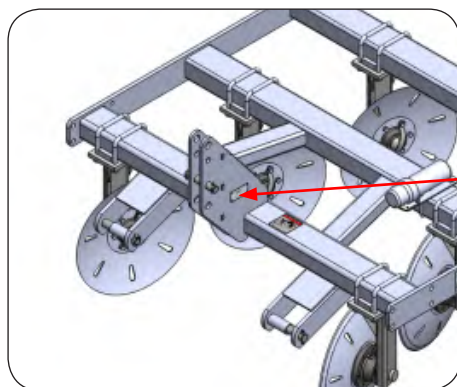

Serial number is located on the left-hand side.

IMPORTANT

The information, specifications, and illustrations in the manual are based on the information available at the time it was written. Due to continuing improvements in the design and manufacture of Unverferth products, all specifications and information contained herein are subject to change without notice.

TABLE OF CONTENTS

Foreword 2
Pre-Delivery Checklist..... 2
Product Information 3

**SECTION I
Safety**

General Hazard Information 1-2
Safety Decals..... 1-3
Following Safety Instructions..... 1-4
Before Servicing 1-4
Before Operating..... 1-4
During Operation..... 1-5
Pressurized Oil..... 1-5
Preparing for Emergencies 1-6
Wearing Protective Equipment..... 1-6

**SECTION II
Set Up**

Set Up 2-2
Mounting Disc Assemblies on 3-Bar Frame 2-3
Guide Cone Stabilizer Assembly 2-4
Guide Cone Stabilizer Hydraulic Lift Assembly Option 2-5
LevelPro Option Assembly 2-7
4-Bar Conversion Option Assembly 2-11
PackerPro Option Assembly 2-16

**SECTION III
Operation**

Preparing Tractor 3-2
Preparing TrackMaster II..... 3-3
 Hardware..... 3-3
 Pivot Pins 3-3
 Guide Cone Stabilizer Hydraulic Lift Option Hydraulics..... 3-3
 Bearings & Disc Blades 3-3
 Lubrication 3-3
Attaching TrackMaster II to Tractor..... 3-4
 Guide Cone Stabilizer Hydraulic Lift Option Hydraulic Hookup 3-4
Transporting 3-4
Unhitching From Tractor 3-5

TABLE OF CONTENTS

SECTION IV
Maintenance

Daily Service.....4-2
 Beginning of Day.....4-2
 End of Day.....4-2
Annual Service.....4-2
 Beginning of Season.....4-2
 End of Season.....4-2
Lubrication4-3
Hub Assembly.....4-3
Complete Torque Chart.....4-4
Hydraulic Fittings.....4-5

SECTION V
Parts

Frame Components & Disc Assembly (J80310051BB)5-2
Disc Assembly Components (J80310012)5-4
Guide Cone Stabilizer Components (J80310014)5-6
Guide Cone Stabilizer Hydraulic Lift Option (J80310035)5-8
LevelPro Option Components (J80310013)5-10
PackerPro Option Components (J80310042)5-12
4-Bar Conversion Option Components (J80310037BB).....5-14

Notes

SECTION I
Safety

General Hazard Information 1-2
Safety Decals..... 1-3
Following Safety Instructions..... 1-4
Before Servicing 1-4
Before Operating..... 1-4
During Operation..... 1-5
Pressurized Oil..... 1-5
Preparing for Emergencies 1-6
Wearing Protective Equipment..... 1-6

General Hazard Information

No accident-prevention program can be successful without the wholehearted cooperation of the person who is directly responsible for the operation of the equipment.

A large number of accidents can be prevented only by the operator anticipating the result before the accident is caused and doing something about it. No power-driven equipment, whether it be transportation or processing, whether it be on the highway, in the field, or in the industrial plant, can be safer than the person who is at the controls. If accidents are to be prevented--and they can be prevented--it will be done by the operators who accept the full measure of their responsibility.

It is true that the designer, the manufacturer, and the safety engineer can help; and they will help, but their combined efforts can be wiped out by a single careless act of the operator.

It is said that, "the best kind of a safety device is a careful operator." We, at Unverferth Mfg. Co., Inc. ask that you be that kind of operator.



REMEMBER:
THINK SAFETY
A CAREFUL OPERATOR IS THE
BEST INSURANCE AGAINST AN
ACCIDENT!

SIGNAL WORDS



INDICATES AN EXTREMELY HAZARDOUS SITUATION OR ACTION THAT WILL RESULT IN SERIOUS INJURY OR DEATH.



INDICATES A HAZARDOUS SITUATION OR ACTION THAT COULD RESULT IN SERIOUS INJURY OR DEATH.



INDICATES AN UNSAFE SITUATION OR ACTION THAT MAY RESULT IN PERSONAL INJURY.





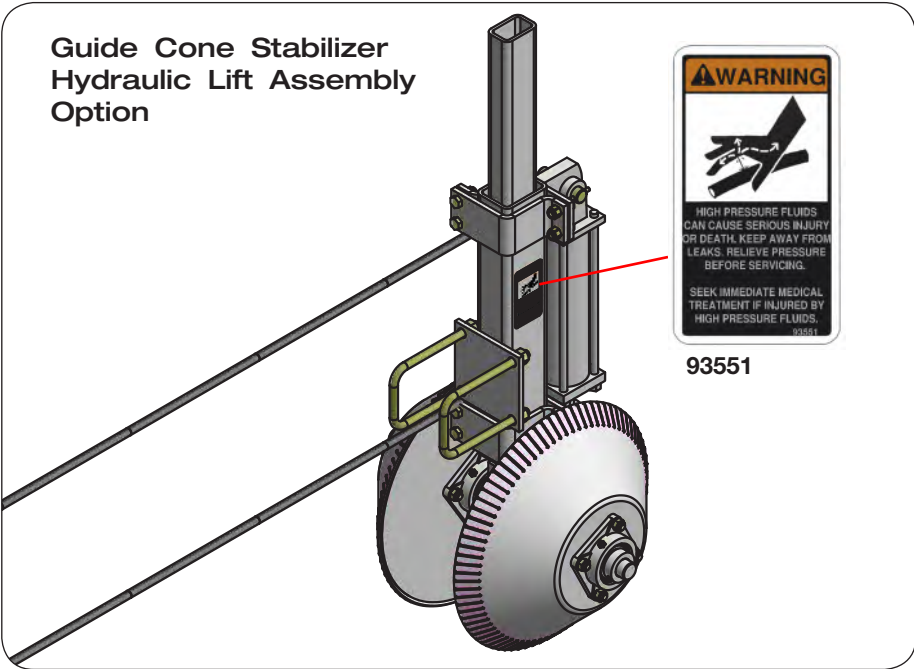
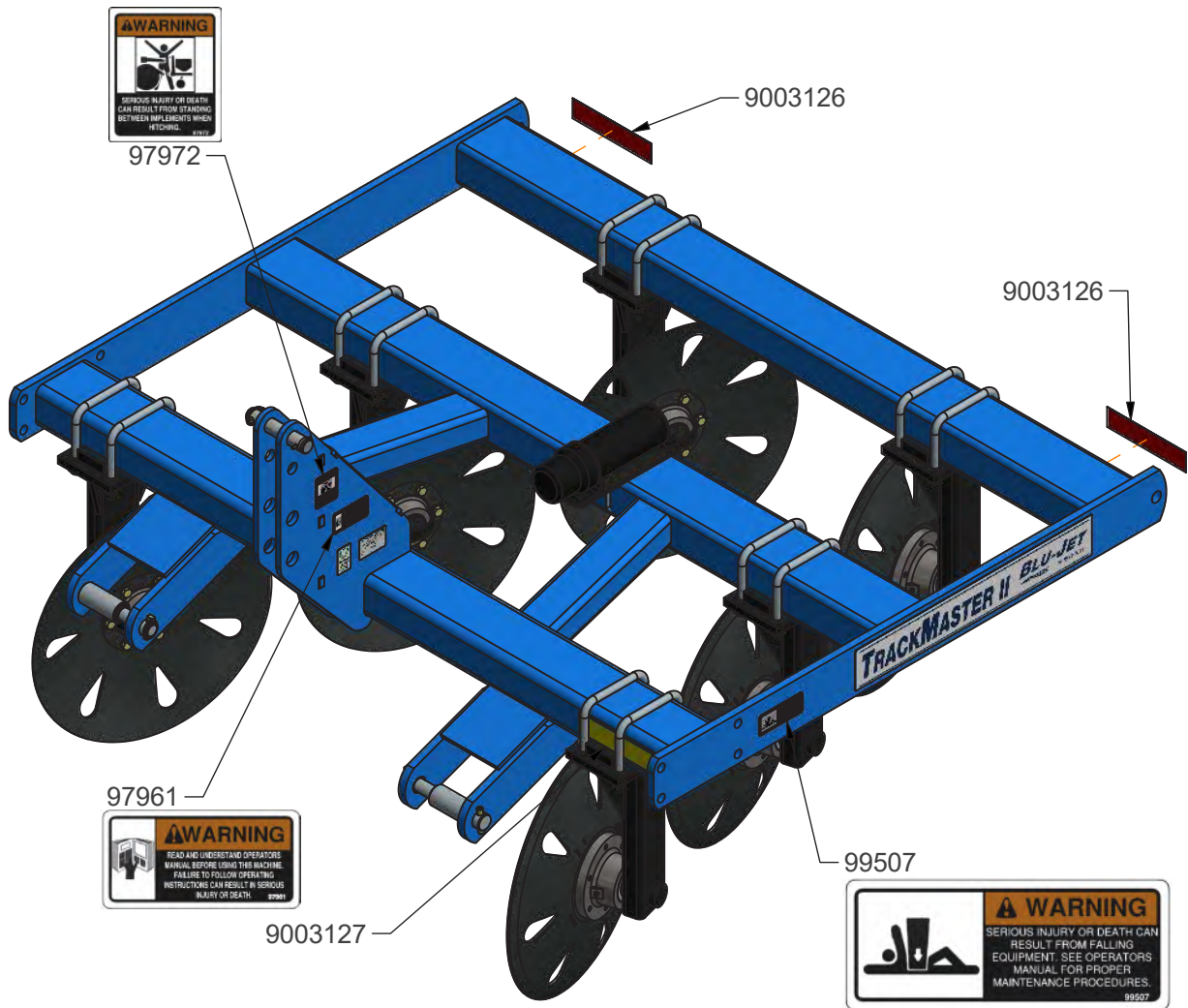

Is used for instruction on operating, adjusting, or servicing a machine.

Safety Decals



Following Safety Instructions

- Read and understand this operator's manual before operating. 
- All machinery should be operated only by trained and authorized personnel.
- To prevent machine damage, use only attachments and service parts approved by the manufacturer.
- Always shut tractor engine off and remove key before servicing. 
- Avoid personal attire such as loose fitting clothing, shoestrings, drawstrings, pants cuffs, long hair, etc., that may become entangled in moving parts.
- Do not allow anyone to ride on the implement. Make sure everyone is clear before operating machine or towing vehicle. 
- Never attempt to operate implement unless you are in driver's seat. 

Before Servicing

- To avoid possible injury, lower implement to the ground before servicing.
- Avoid working under an implement; however, if it becomes absolutely unavoidable, make sure the implement is safely blocked. 
- Ensure that all applicable safety decals are installed and legible.
- When working around the implement, be careful not to be cut by sharp edges.

Before Operating

- Do not stand between tractor and implement during hitching.
- When working around the implement, be careful not to be cut by sharp edges.
- Always make certain everyone and everything is clear of the machine before beginning operation.
- Inspect fields for buried utility lines (electric, natural gas, water, etc.). To find buried lines in the US or Canada contact 1-888-258-0808, in the US you may also contact 811.

During Operation

- Do not allow anyone to ride on the equipment. Never dismount from moving vehicle. Severe injury or death can occur from being run over by the equipment. 
- Regulate speed to field conditions. Maintain complete control at all times.
- Never service or lubricate equipment when in operation.
- Keep away from overhead power lines. Electrical shock can cause serious injury or death.
- Do not attempt to move any objects away from moving parts.
- Avoid personal attire such as loose fitting clothing, shoestrings, drawstrings, pants cuffs, long hair, etc. that may become entangled in moving parts.
- Use extreme care when operating close to ditches, fences, or on hillsides.
- Do not leave towing vehicle unattended with engine running.

Pressurized Oil

- Relieve the hydraulic system of all pressure before adjusting or servicing. See hydraulic power unit manual for procedure to relieve pressure.
- High-pressure fluids can penetrate the skin and cause serious injury or death. Use cardboard or wood to detect leaks in the hydraulic system. Seek medical treatment immediately if injured by high-pressure fluids.
- Hydraulic system must be purged of air before operating to prevent serious injury or death.
- Do not bend or strike high-pressure lines. Do not install bent or damaged tubes or hoses.
- Repair all oil leaks. Leaks can cause fires, personal injury, and environmental damage.
- Route hoses and lines carefully to prevent premature failure due to kinking and rubbing against other parts. Make sure that all clamps, guards and shields are installed correctly.
- Check hydraulic hoses and tubes carefully. Replace components as necessary if any of the following conditions are found:
 - End fittings damaged, displaced, or leaking.
 - Outer covering chafed/cut or wire reinforcing exposed.
 - Outer covering ballooning locally.
 - Evidence of kinking or crushing of the flexible part of a hose.

Preparing for Emergencies

- Keep a first aid kit and properly rated fire extinguisher nearby.



- Keep emergency numbers for fire, rescue, and poison control personnel near the phone.



Wearing Protective Equipment

- Wear clothing and personal protective equipment appropriate for the job.



- Wear steel-toed shoes when operating.



- Wear hearing protection when exposed to loud noises.



- Do not wear additional hearing impairing devices such as radio headphones, etc.



SECTION II
Set Up

Set Up2-2
Mounting Disc Assemblies on 3-Bar Frame2-3
Guide Cone Stabilizer Assembly2-4
Guide Cone Stabilizer Hydraulic Lift Assembly Option2-5
LevelPro Option Assembly2-7
4-Bar Conversion Option Assembly2-11
PackerPro Option Assembly2-16

Set Up

WARNING

- **READ AND UNDERSTAND SAFETY RULES BEFORE OPERATING OR SERVICING THIS MACHINE. REVIEW THE SAFETY SECTION IN THIS MANUAL IF NECESSARY.**

- **TIPPING OR MOVEMENT OF THE MACHINE CAN CAUSE SERIOUS INJURY OR DEATH. BE SURE THE MACHINE IS SECURELY BLOCKED.**

- **KEEP HANDS CLEAR OF PINCH POINT AREAS.**

- **FALLING OBJECTS CAN CAUSE SERIOUS INJURY OR DEATH. DO NOT WORK UNDER THE MACHINE AT ANY TIME WHILE BEING HOISTED. BE SURE ALL LIFTING DEVICES AND SUPPORTS ARE RATED FOR THE LOADS BEING HOISTED. THESE ASSEMBLY INSTRUCTIONS WILL REQUIRE SAFE LIFTING DEVICES UP TO 1,500 LBS. SPECIFIC LOAD RATINGS FOR INDIVIDUAL LOADS WILL BE GIVEN AT THE APPROPRIATE TIME IN THE INSTRUCTIONS.**

- **EYE PROTECTION AND OTHER APPROPRIATE PERSONAL PROTECTIVE EQUIPMENT MUST BE WORN WHILE SERVICING THE IMPLEMENT.**

For your safety, and the safety of others, use proper tools and equipment and always use safe working procedures. Refer to these instructions before starting any work on the machine.

For ease of assembly, install all hardware loosely until assembly is complete and then tighten according to Torque Chart in the MAINTENANCE section of this manual.

Mounting Disc Assemblies on 3-Bar Frame

1. Using a safe lifting device and supports rated at a minimum of 1,500 lbs., place main frame on supports 36" to 42" high at each end.
2. Using a safe lifting device rated at a minimum of 100 lbs., mount the disc assemblies as shown in FIG. 2-1. Secure with 3/4"-10UNC x 5 11/16" U-bolts (JBP3208), and 3/4"-10UNC lock nuts (9802). Torque hardware according to "Torque Chart" in the MAINTENANCE section.

NOTE: Disc assemblies throwing soil to the left are mounted on the right-hand side of the machine.

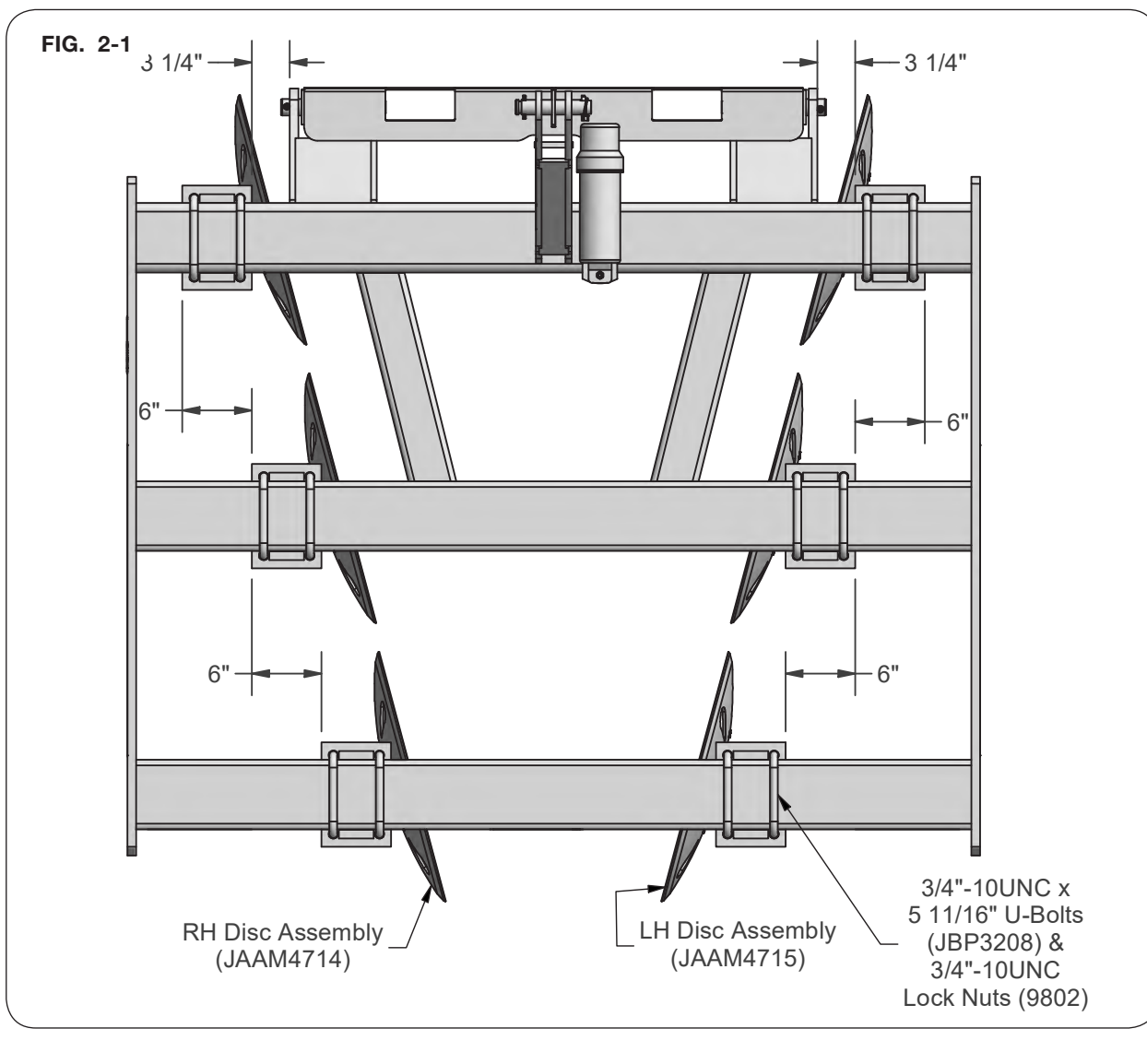

Guide Cone Stabilizer Assembly

1. Position the guide cone stabilizer mounting bracket weldment (JAM4772) around the 3rd link riser facing to the rear of the frame.
2. Secure mounting bracket weldment (JAM4772) with 5/8"-11UNC x 7 1/2" U-bolts (JBP3331) and 5/8"-11UNC lock nuts (9801) (FIG. 2-2). Torque hardware according to "Torque Chart" in the MAINTENANCE section.

FIG. 2-2

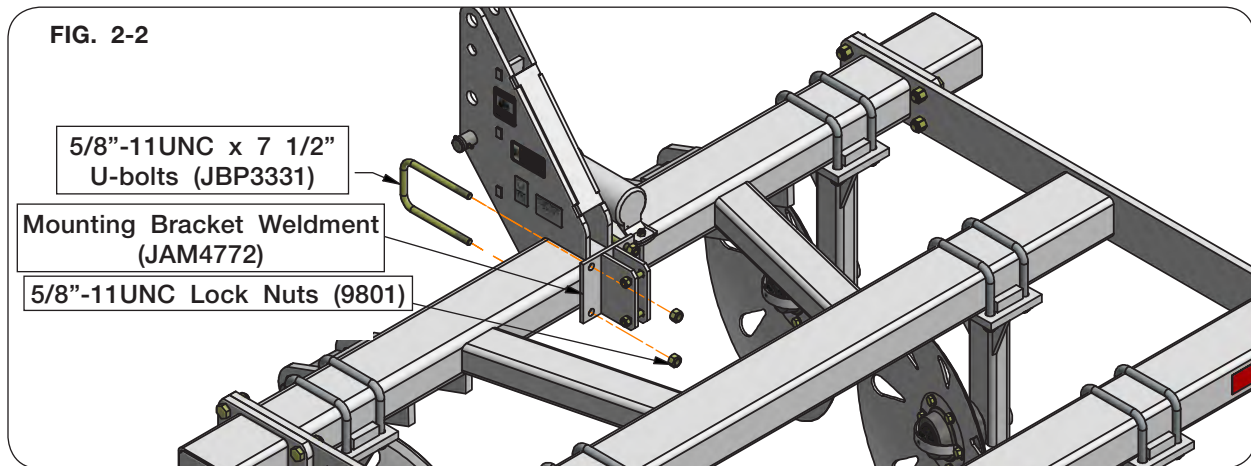

3. Using a safe lifting device rated at a minimum of 150 lbs., raise the guide cone stabilizer assembly until even with the bottom of the disc blades (FIG. 2-3). Secure the guide cone stabilizer assembly to the mounting bracket weldment (JAM4772) with 1/2"-13UNC x 2 1/2" carriage bolts (9388-108) and 1/2"-13UNC lock nuts (9800) (FIG. 2-4). Torque hardware according to "Torque Chart" in the MAINTENANCE section.

FIG. 2-3

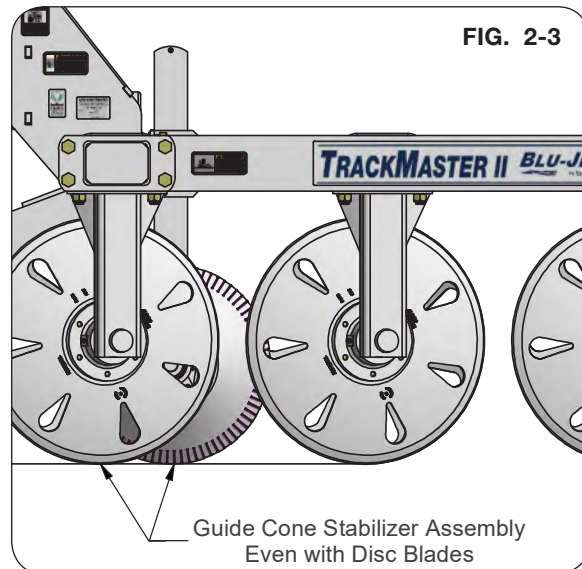
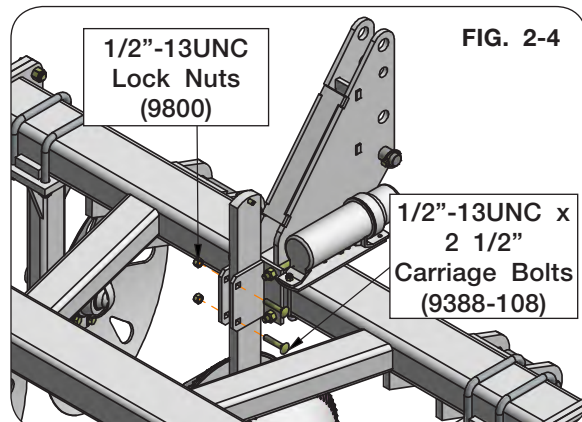
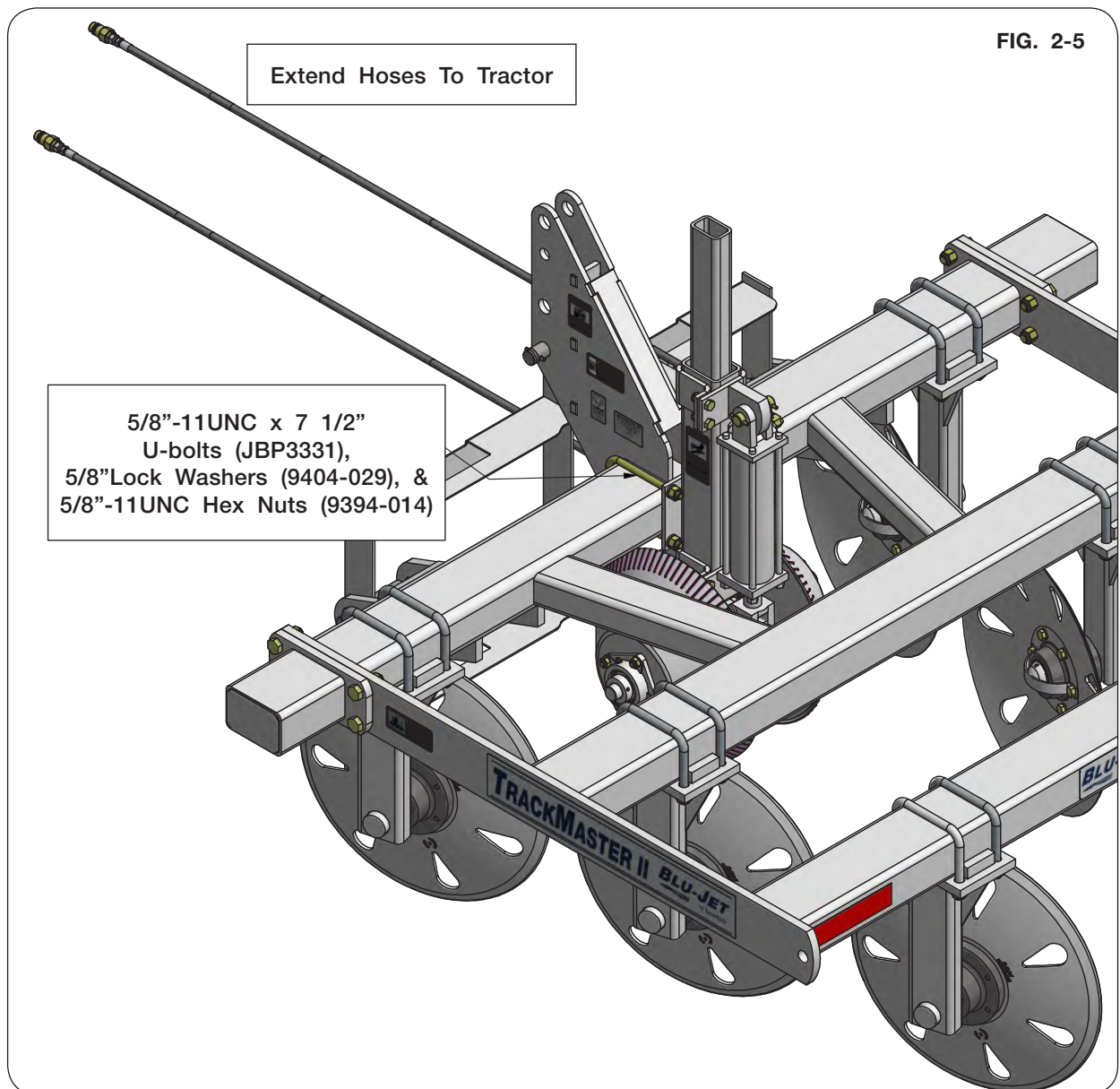

FIG. 2-4



Guide Cone Stabilizer Hydraulic Lift Assembly Option

1. Remove the 5/8"-11UNC x 7 1/2" U-bolts (JBP3331), 5/8" lock washers (9404-029), and 5/8"-11UNC hex nuts (9394-014) from the guide cone stabilizer hydraulic lift assembly.
2. Using a safe lifting device rated at a minimum of 300 lbs., raise the guide cone stabilizer hydraulic lift assembly to the center of the front frame as shown in FIG. 2-5.
3. Secure into position with the 5/8"-11UNC x 7 1/2" U-bolts (JBP3331), 5/8" lock washers (9404-029), and 5/8"-11UNC hex nuts (9394-014) (FIG. 2-5). Torque hardware according to "Torque Chart" in the MAINTENANCE section.
4. Extend hoses to the tractor.



Guide Cone Stabilizer Hydraulic Lift Assembly Option (continued)

Purging Hydraulic System

WARNING

- RELIEVE HYDRAULIC SYSTEM OF ALL PRESSURE BEFORE ADJUSTING OR SERVICING. SEE TRACTOR OPERATOR'S MANUAL FOR PROPER PROCEDURES.
- HIGH-PRESSURE FLUIDS CAN PENETRATE THE SKIN AND CAUSE SERIOUS INJURY OR DEATH. USE CARDBOARD OR WOOD TO DETECT LEAKS IN THE HYDRAULIC SYSTEM. SEEK MEDICAL TREATMENT IMMEDIATELY IF INJURED BY HIGH-PRESSURE FLUIDS.

Purge air from system as follows:

- A. Pressurize the system and maintain system at full pressure for at least 5 seconds after the cylinder rod stops moving. Check that the cylinder has fully extended or retracted.
- B. Check oil reservoir in hydraulic power source and re-fill as needed.
- C. Pressurize system again to reverse the motion of step B. Maintain pressure on system for at least 5 seconds after the cylinder rod stops moving. Check the cylinder has fully extended or retracted.
- D. Check for hydraulic leaks using cardboard or wood. Tighten connections according to directions in Torque Specifications in MAINTENANCE section.
- E. Repeat steps A, B, C, and D 3-4 times.

HYDRAULIC SYSTEM CHECKS ON ALL UNITS -- CHECK THE FOLLOWING:

ROUTING OF ALL HYDRAULIC HOSES: Hoses should not be kinked, twisted, or rubbing against sharp edges.

FITTINGS AND CONNECTIONS: Check for leaks. Refer to "Torque Chart" in MAINTENANCE section.

LevelPro Option Assembly

1. Using a safe lifting device rated at a minimum of 50 lbs., position offset stagger bracket weldments (JAM2394) to the rear tube of the TrackMaster as shown in FIG. 2-6.

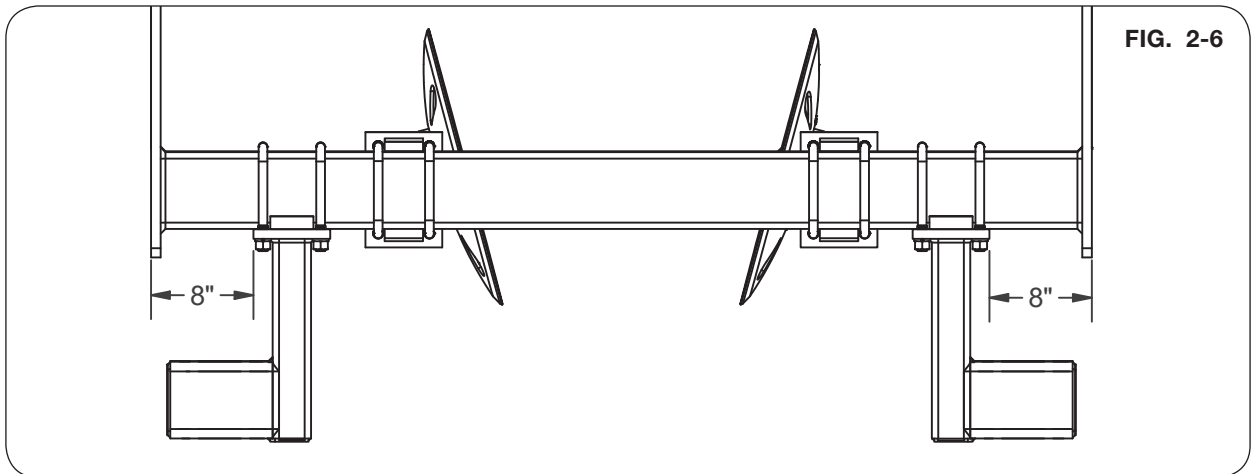

2. Secure with 3/4"-10UNC x 7 3/4" U-bolts (JBP3047) and 3/4"-10UNC lock nuts (9802) (FIG. 2-7). Torque hardware according to "Torque Chart" in the MAINTENANCE section.

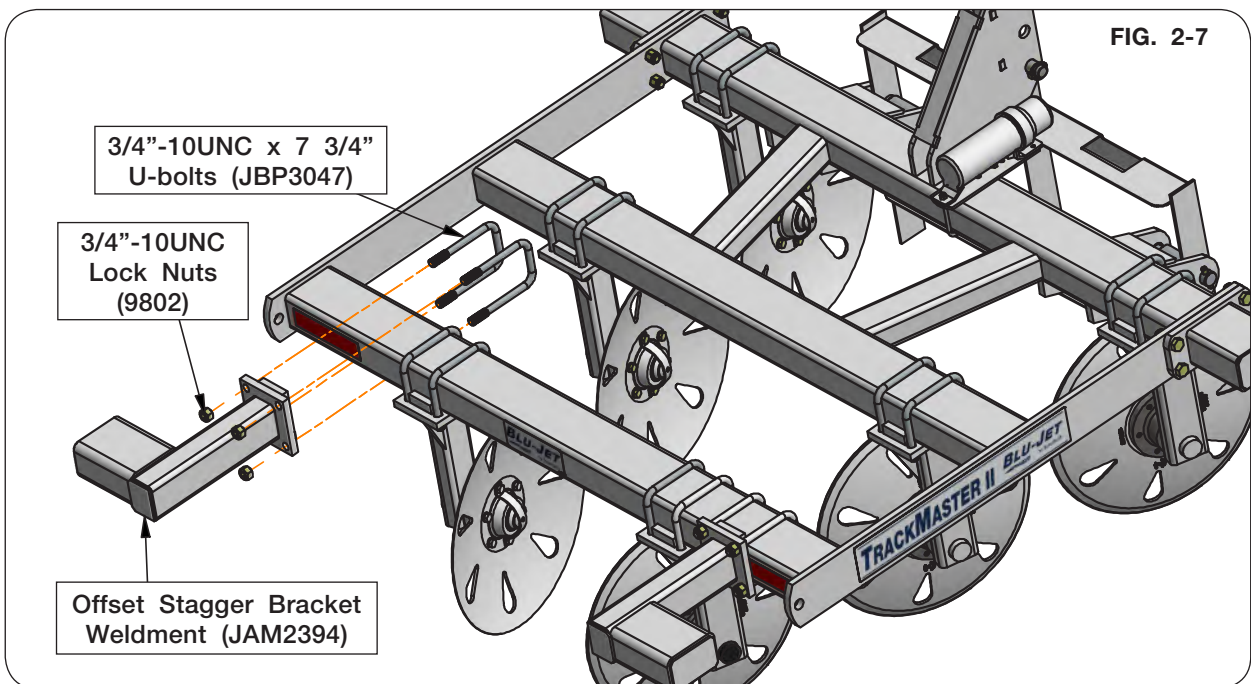

LevelPro Option Assembly (continued)

- Center the mounting plates (JAM7637) on the bottom of the offset stagger bracket weldments (JAM2394). Secure with 3/4"-10UNC x 5 11/16" U-bolts (JBP3208), 3/4" lock washers (9404-033), and 3/4"-10UNC hex nuts (9394-016) (FIG. 2-8). Torque hardware according to "Torque Chart" in the MAINTENANCE section.

FIG. 2-8

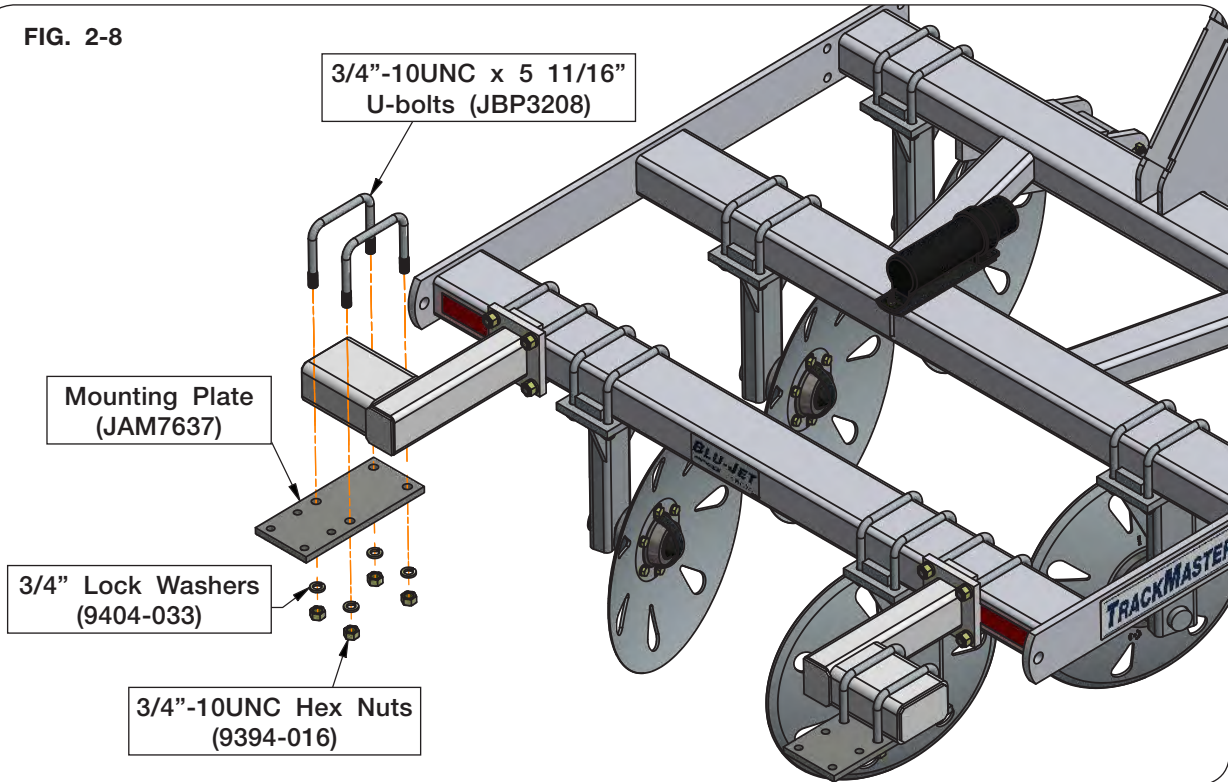

LevelPro Option Assembly (continued)

4. Attach the reflectors, RED (9003126), to the torsion spring weldments (JAM4921 & JAM4922). (FIG. 2-10)
5. Loosely attach the torsion spring weldment left-hand (JAM4921) to the top of the mounting plate (JAM7637) on the left-hand side with 5/8"-11UNC x 4" U-bolts (JBP3300), 5/8" lock washers (9404-029), and 5/8"-11UNC hex nuts (9394-014). (FIG. 2-9 & FIG. 2-10)
6. Loosely attach the torsion spring weldment right-hand (JAM4922) to the top of the mounting plate (JAM7637) on the right-hand side with 5/8"-11UNC x 4" U-bolts (JBP3300), 5/8" lock washers (9404-029), and 5/8"-11UNC hex nuts (9394-014). (FIG. 2-10)

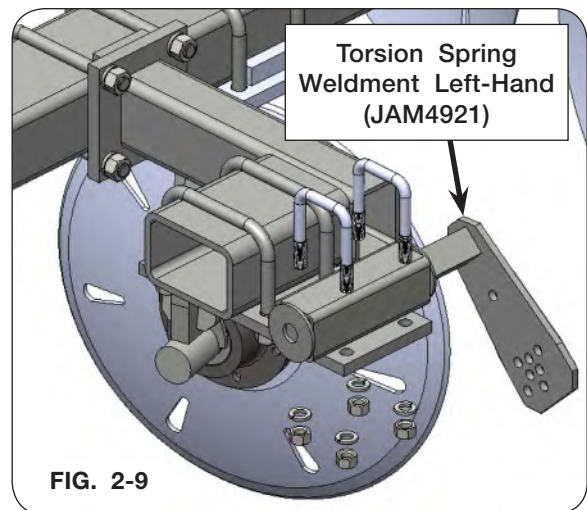

FIG. 2-9

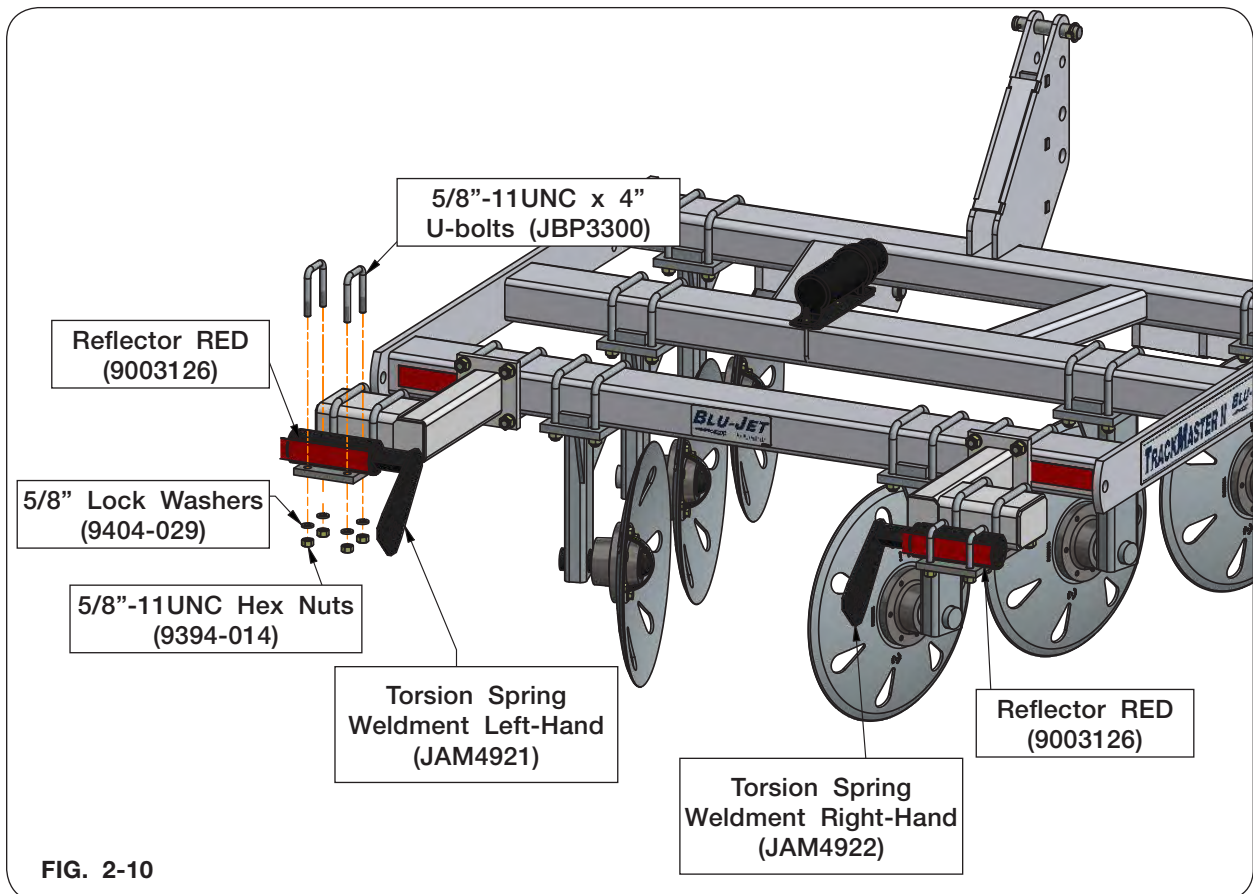

FIG. 2-10

LevelPro Option Assembly (continued)

- Using a safe lifting device rated at a minimum of 300 lbs., center the leveler coil assembly with leveler mounting plates and flange bearings in between the torsion spring weldments (JAM4921 & JAM4922). (FIG. 2-11)

NOTE: The leveler coil assembly spiral must face towards the front. (FIG. 2-11)

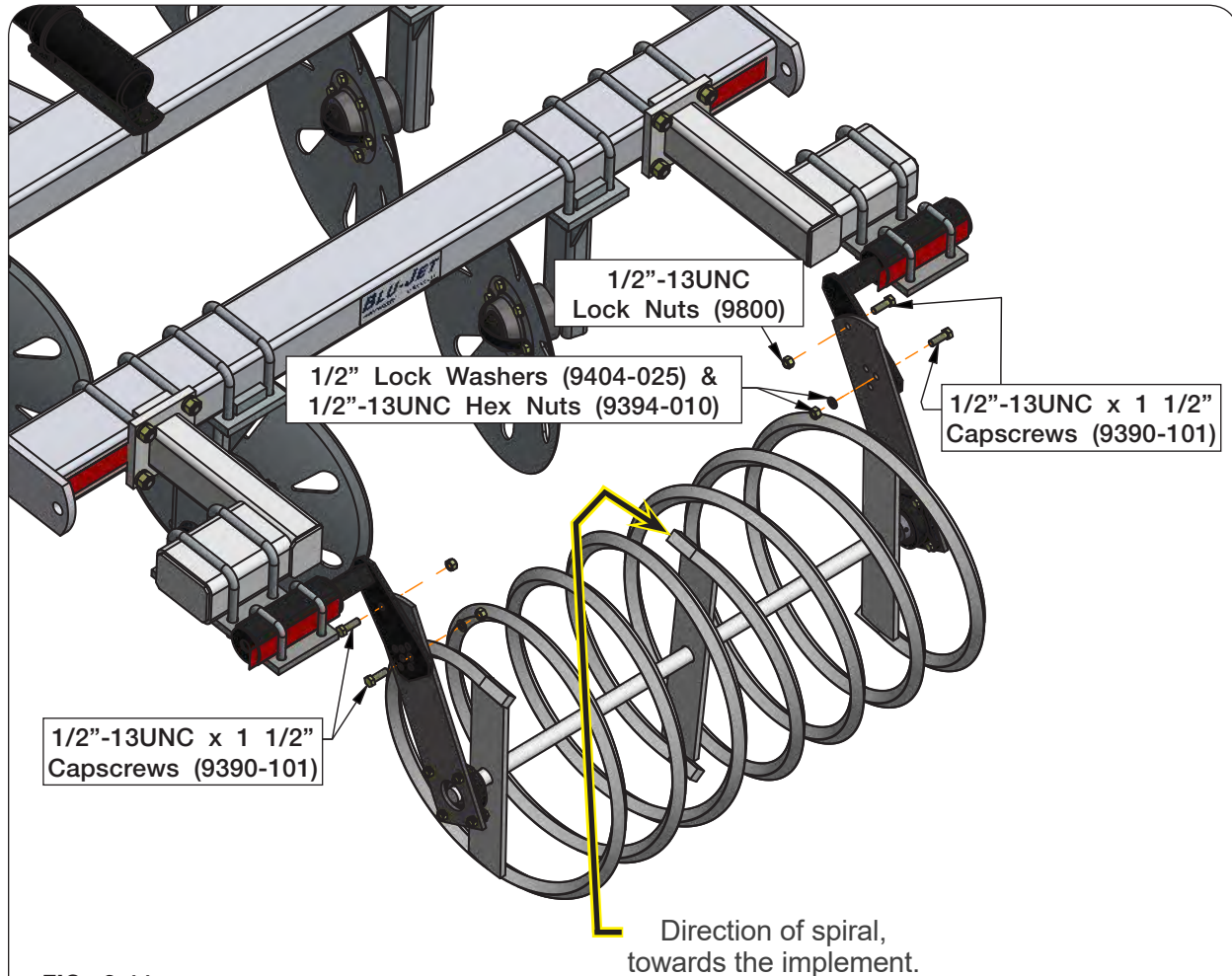
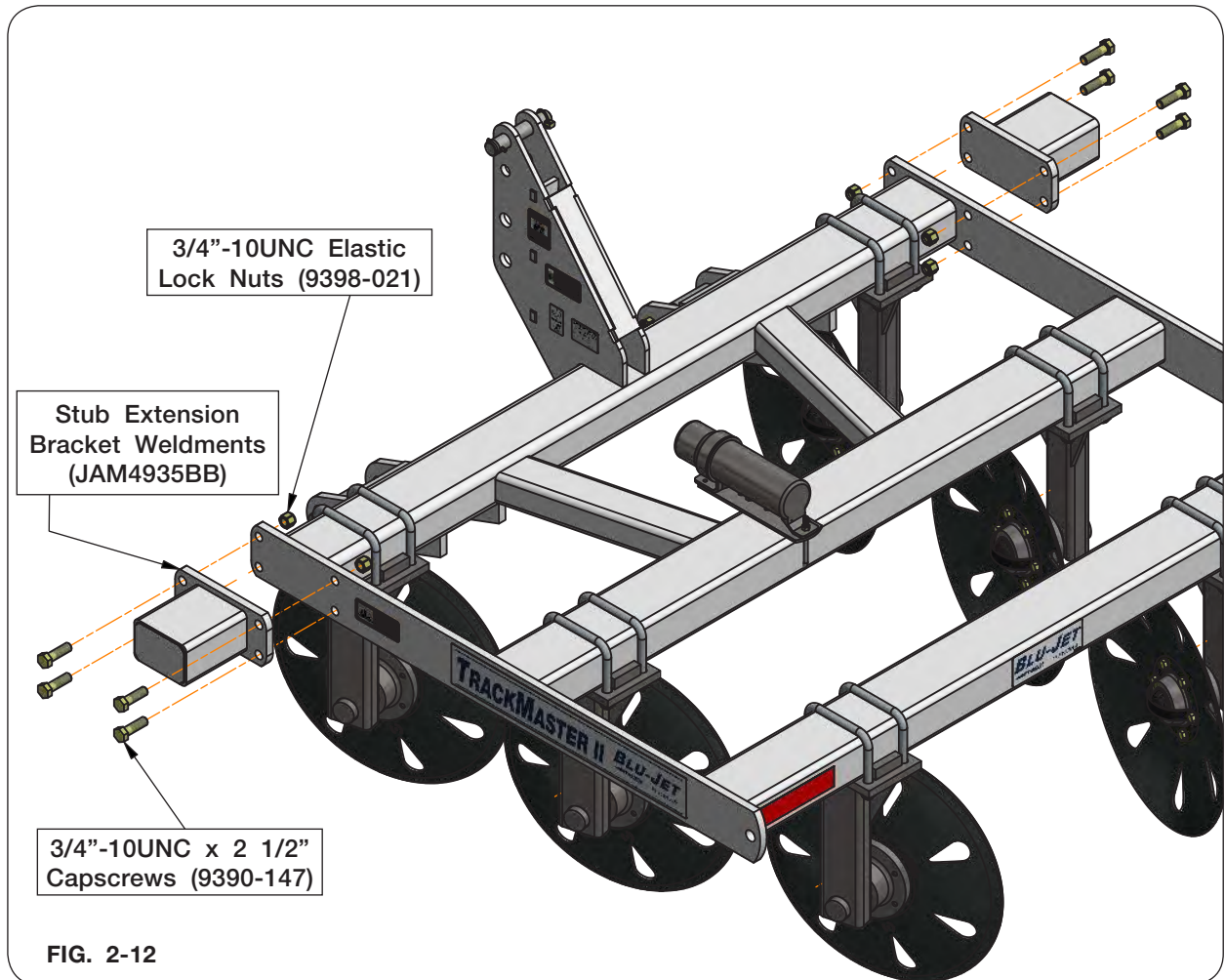

FIG. 2-11

- Loosely secure the leveler mounting plates to the top holes on the torsion spring weldments (JAM4921 & JAM4922) with 1/2"-13UNC x 1 1/2" capscrews (9390-101) and 1/2"-13UNC lock nuts (9800). (FIG. 2-11)
- Torque U-bolts attached in steps 5 & 6 according to "Torque Chart" in the MAINTENANCE section. Make sure the mounting brackets are equally positioned.
- Adjust the leveler mounting arms up or down until the desired leveling is achieved. Align the lower holes and insert 1/2"-13UNC x 1 1/2" capscrews (9390-101), 1/2" lock washers (9404-025), and 1/2"-13UNC hex nuts (9394-010). (FIG. 2-11)
- Torque all hardware according to "Torque Chart" in the MAINTENANCE section.

4-Bar Conversion Option Assembly

1. Attach the stub extension bracket weldments (JAM4935BB) to the 3-bar frame sides with 3/4"-10UNC x 2 1/2" capscrews (9390-147) and 3/4"-10UNC elastic lock nuts (9398-021). (FIG. 2-12)



4-Bar Conversion Option Assembly (continued)

- Using a safe lifting device rated at a 100 lbs., loosen the 3/4"-10UNC x 5 11/16" U-bolts (JBP3208) and 3/4"-10UNC lock nuts (9802). Reposition left-hand and right-hand disc assemblies in rows 1 and 2 as shown in FIG. 2-13.

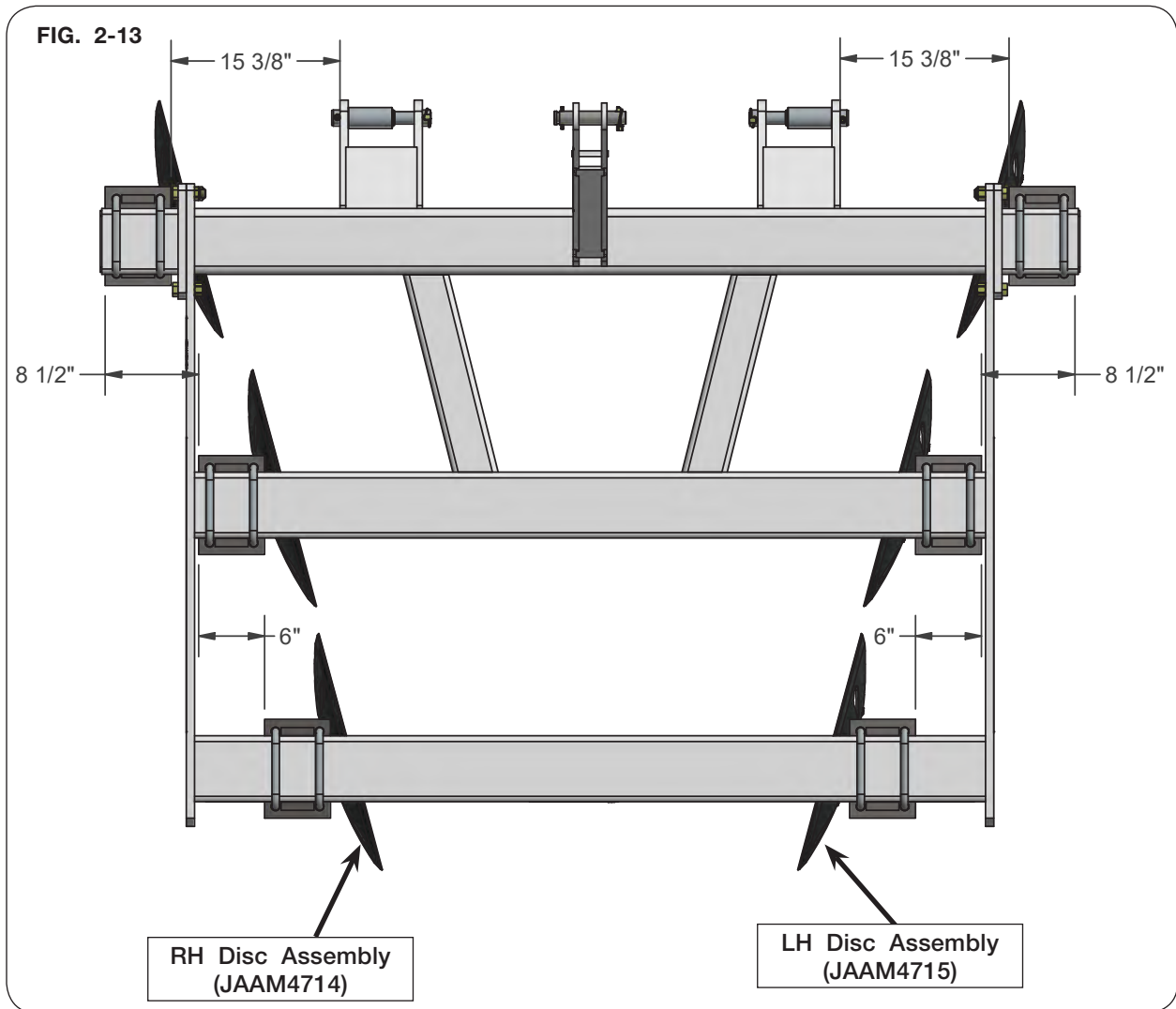

- Using a safe lifting device rated at a 100 lbs., loosen the 3/4"-10UNC x 5 11/16" U-bolts (JBP3208) and 3/4"-10UNC lock nuts (9802). Reposition left-hand and right-hand disc assemblies in row 3 as shown in FIG. 2-13.

4-Bar Conversion Option Assembly (continued)

4. Using a safe lifting device rated at a minimum of 50 lbs., relocate the 20" extension bracket weldments (JAM3400BB) to the outer-most position by loosening the 3/4"-10UNC x 7 3/4" U-bolts (JBP3047) and 3/4"-10UNC elastic lock nuts (9398-021). (FIG. 2-15)
5. Using a safe lifting device rated at a minimum of 400 lbs., position the bolt-on 4-bar weldment (JAM4927BB), disc assemblies (JAAM4714 & JAAM4715), and 20" extension bracket weldments (JAM3400BB) to the rear of the 3-bar frame. (FIG. 2-15)

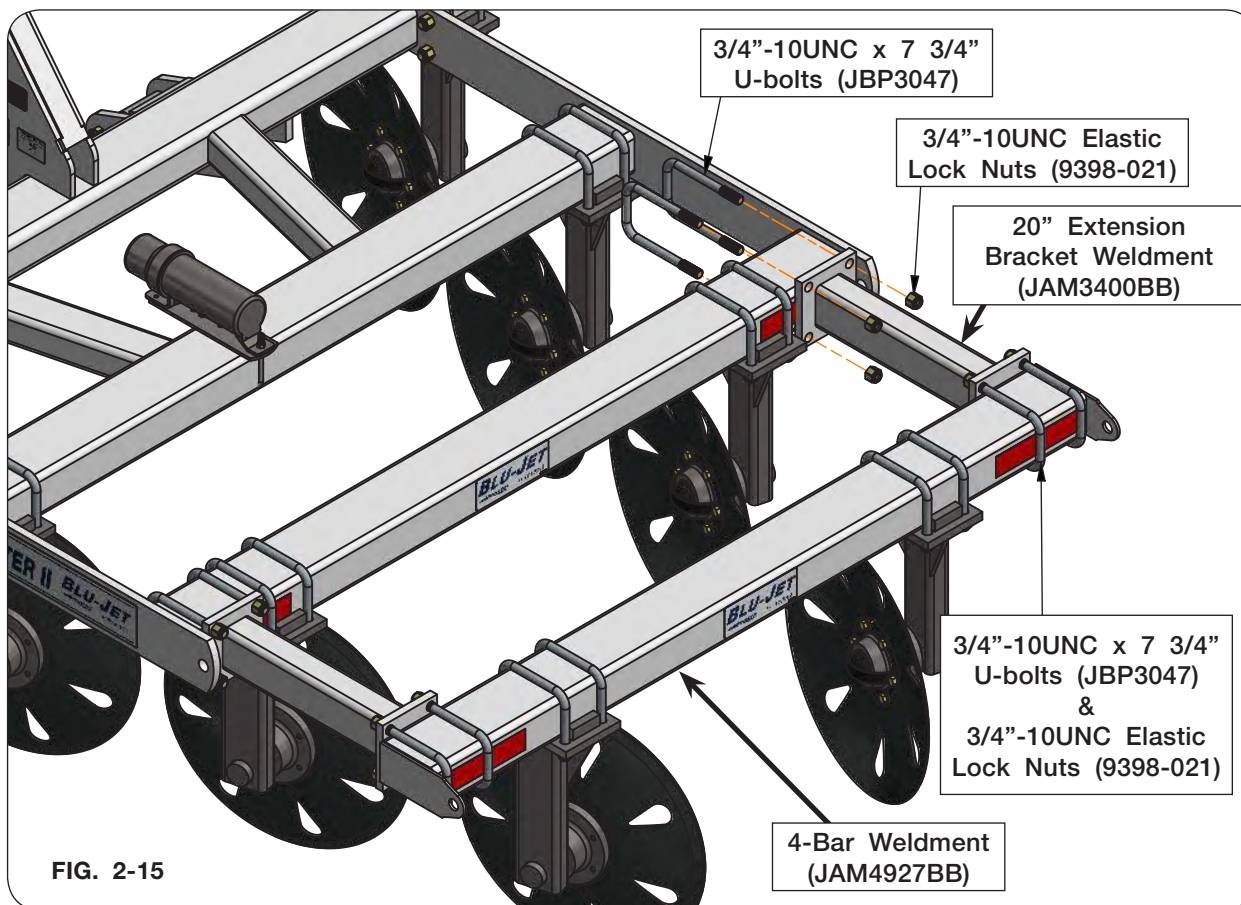

4-Bar Conversion Option Assembly (continued)

- Using a safe lifting device rated at a 100 lbs., loosen the 3/4"-10UNC x 5 11/16" U-bolts (JBP3208) and 3/4"-10UNC lock nuts (9802) (FIG. 2-16). Relocate the disc assemblies as shown in FIG. 2-17.

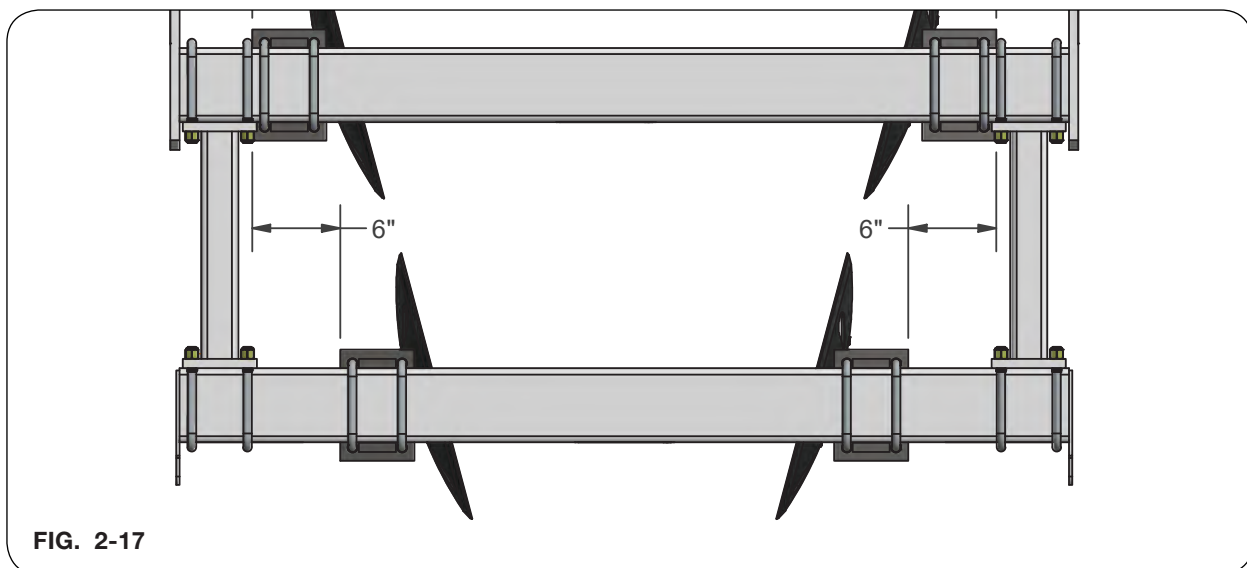
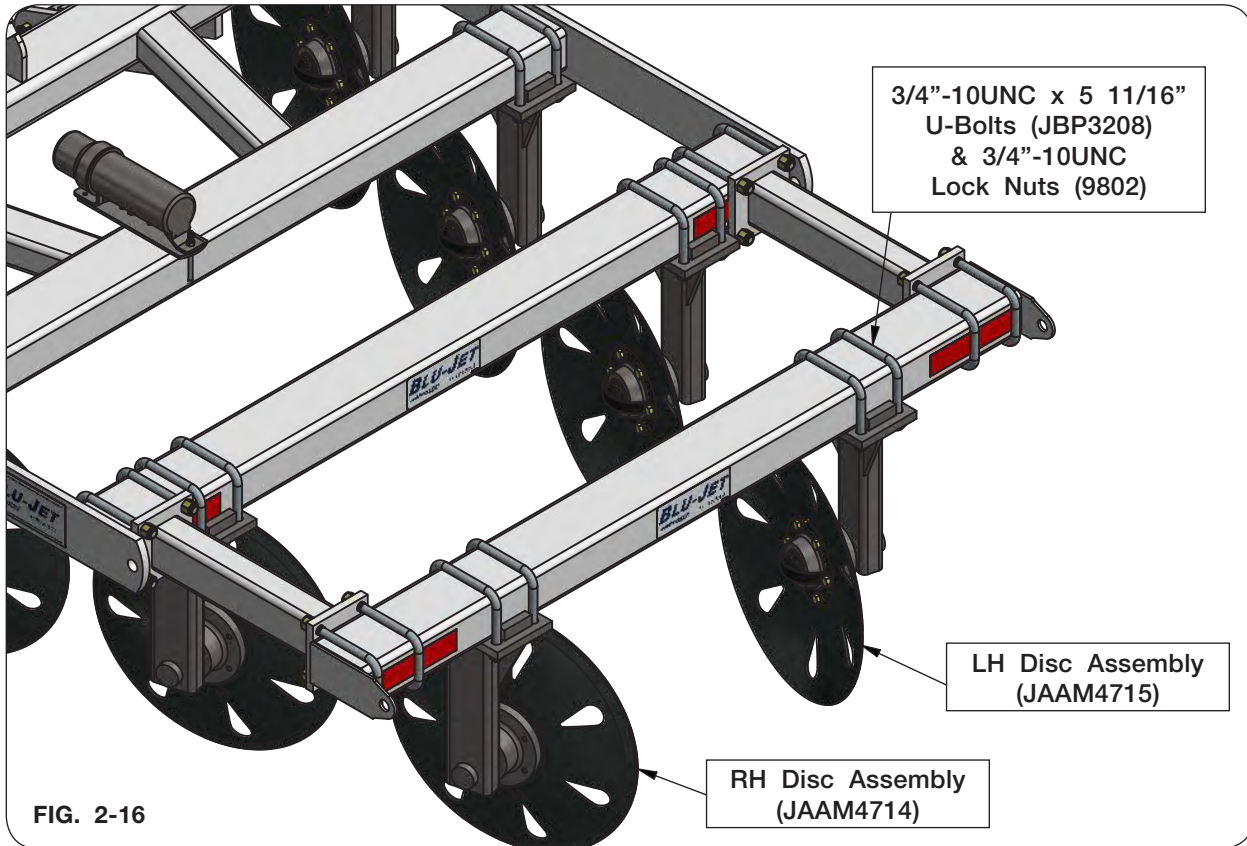

- Torque all hardware according to "Torque Chart" in the MAINTENANCE section.

PackerPro Option Assembly

1. Center the basket mounting plate (JAM7637) on the third frame bar. Mounting bracket must be offset forward of the third bar. Loosely secure with two 3/4"-10UNC x 5 11/16" U-bolts (JBP3208) and 3/4"-10UNC lock nuts (9802) (FIG. 2-18).

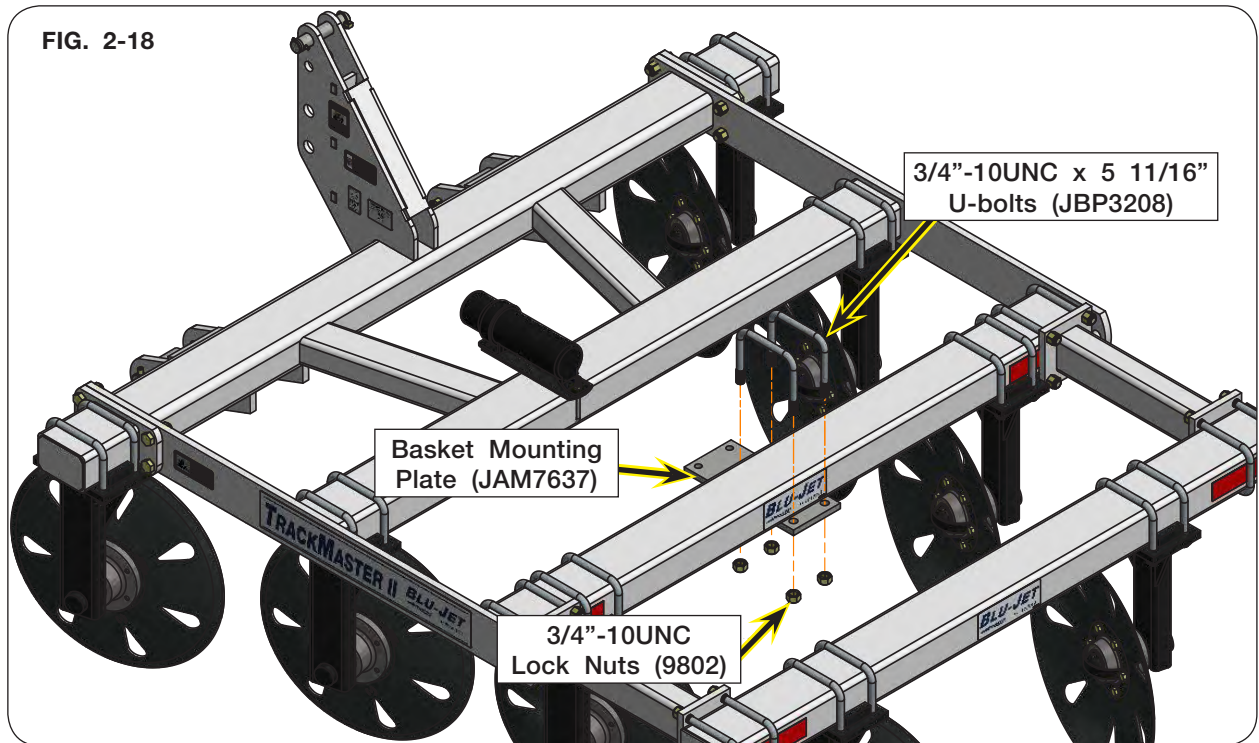

2. Using a safe lifting device rated at a minimum of 100 lbs., loosely attach the basket mount assembly to the basket mounting plate (JAM7637) as shown in FIG. 2-19.

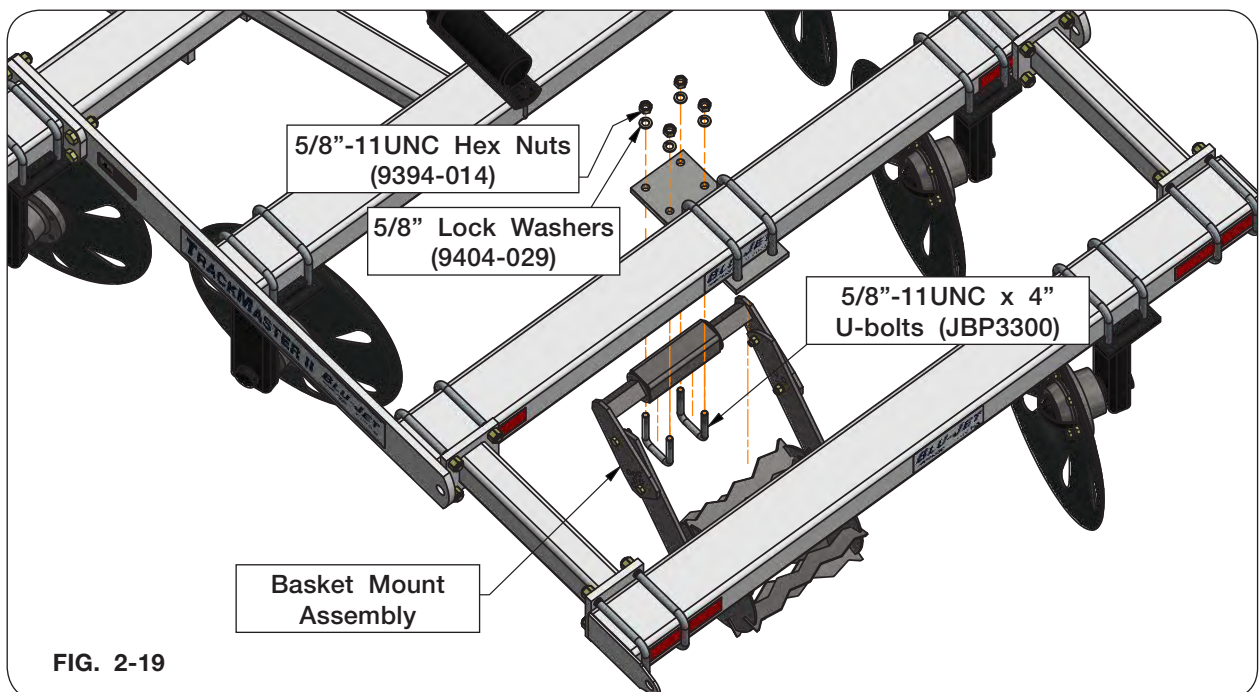
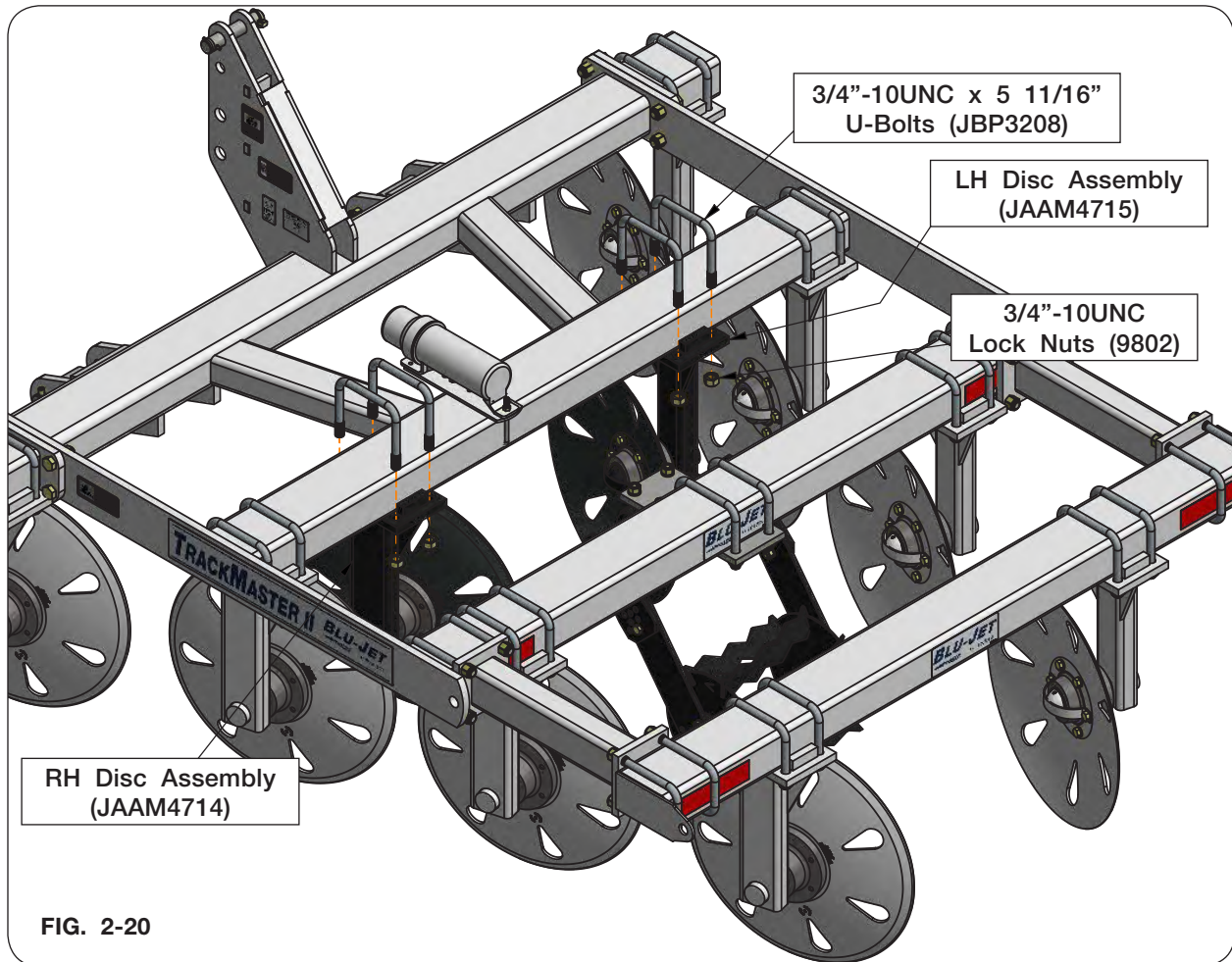

FIG. 2-19

PackerPro Option Assembly (continued)

- Using a safe lifting device rated at a 100 lbs., position the disc assemblies on the second frame bar FIG. 2-20. Loosely secure using 3/4"-10UNC x 5 11/16" U-bolts (JBP3208) and 3/4"-10UNC lock nuts (9802).



PackerPro Option Assembly (continued)

4. Verify location of basket mount assembly and disc assemblies with FIG. 2-21.

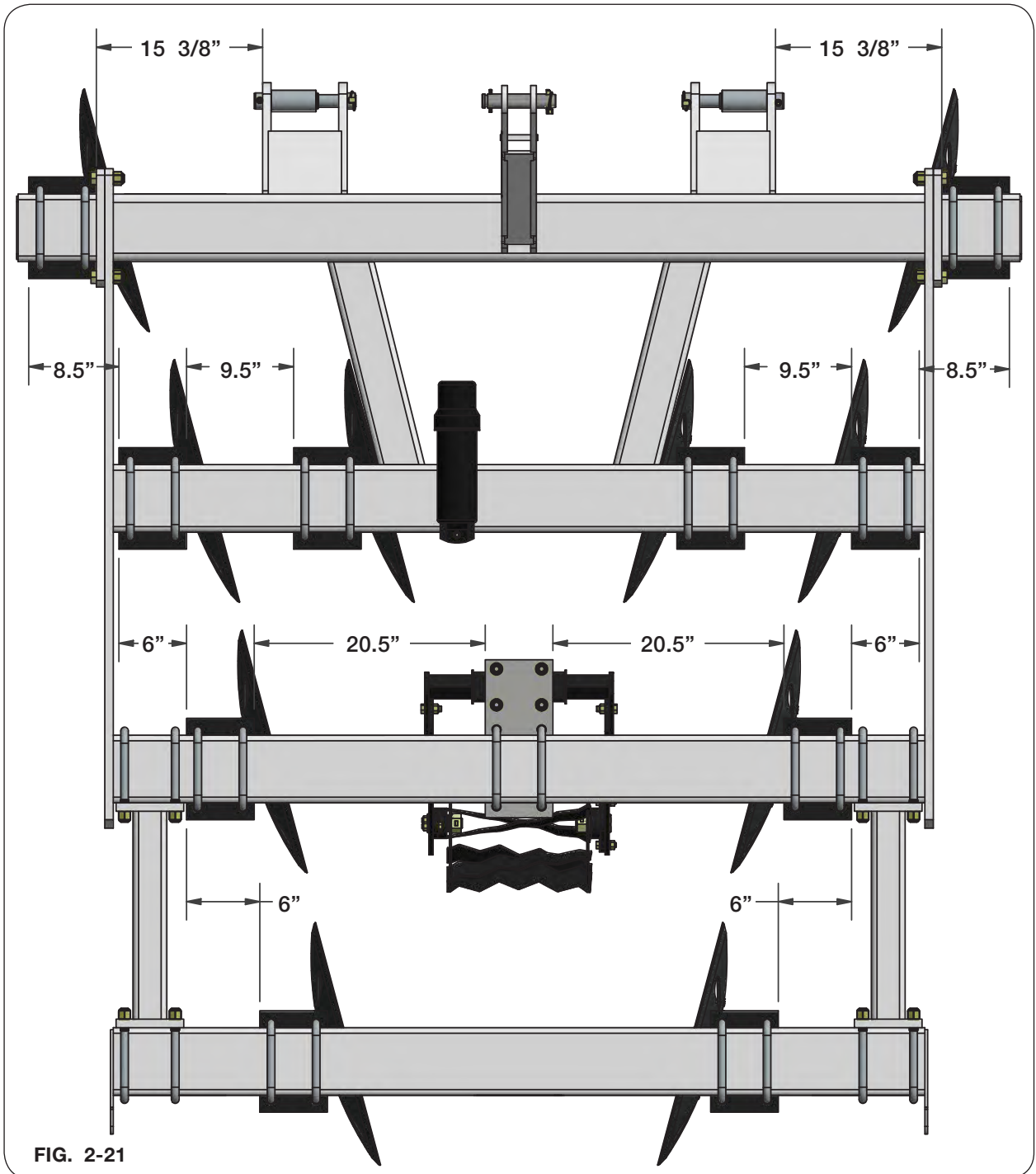

5. Torque all hardware according to "Torque Chart" in the MAINTENANCE section.

Notes

SECTION III
Operation

Preparing Tractor 3-2
Preparing TrackMaster II..... 3-3
 Hardware..... 3-3
 Pivot Pins 3-3
 Guide Cone Stabilizer Hydraulic Lift Option Hydraulics..... 3-3
 Bearings & Disc Blades 3-3
 Lubrication 3-3
Attaching TrackMaster II to Tractor..... 3-4
 Guide Cone Stabilizer Hydraulic Lift Option Hydraulic Hookup 3-4
Transporting 3-4
Unhitching From Tractor 3-5

Preparing Tractor

Before operating implement refer to tractor operator's manual for information concerning safe methods of operation, and tire inflation.

Check tractor brakes and transport lights. Make sure they are in proper working order.

Check tractor hydraulic oil reservoir and add oil if needed.

WARNING

- **TRANSPORTING THE IMPLEMENT SIGNIFICANTLY CHANGES THE WEIGHT AND BALANCE OF YOUR TRACTOR. MAKE SURE THE TRACTOR IS PROPERLY BALLASTED.**

Measure tractor linkages on pull arms to insure equal length for level operation as viewed across the rear of the tractor. Check tire pressure for equal inflation.

Remove sway bars.

Mount TrackMaster frame onto the tractor pull arms. Be certain the proper pins are used in either CAT2/3 hookup if quick hitch is not used.

Attach third link if quick hitch is not used.

Adjust third link until the frame operates level at the desired working depth.

Position tractor and TrackMaster over track. Lower TrackMaster guide cones to desired depth (typically even with blades). Lower into track and begin operation. Tractor speed can vary with soil conditions. Cones can be adjusted until desired track fill is accomplished.

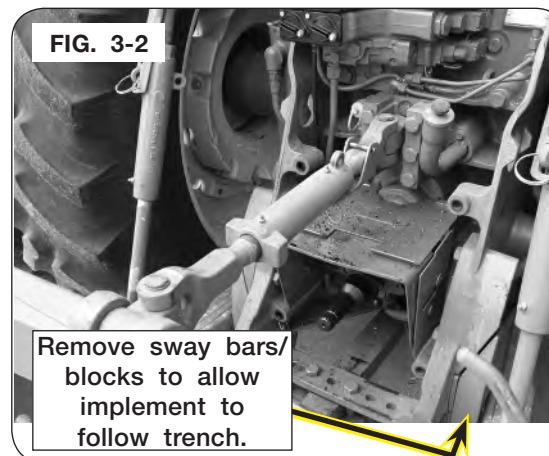
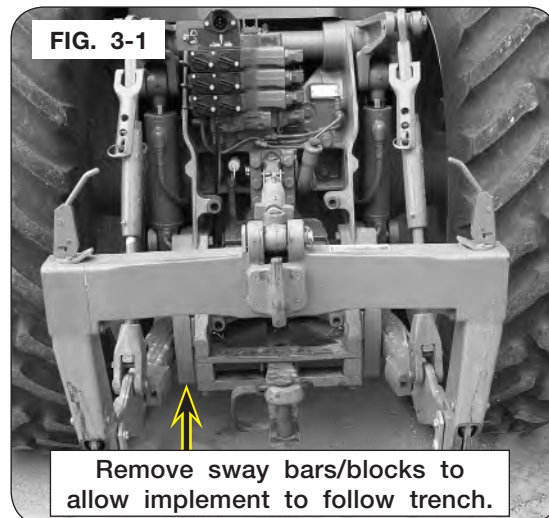

Preparing TrackMaster II

Perform the service checks as outlined. Repair or replace any damaged or worn parts before operating.

Hardware

Check for loose bolts and nuts, and tighten as needed. Check again after the first half-day of operation.

Pivot Pins

Check that all pins are in place and in good condition. Replace any worn, damaged or missing pins.

Guide Cone Stabilizer Hydraulic Lift Option

Check routing of all hydraulic hoses. Hoses should not be kinked, twisted, or rubbing against sharp edges. Hoses should be secure with tie straps.

Check hoses and fittings for hydraulic leaks. Tighten or replace as required.

WARNING

- **HIGH-PRESSURE FLUIDS CAN PENETRATE THE SKIN AND CAUSE SERIOUS INJURY OR DEATH. USE CARDBOARD OR WOOD TO DETECT LEAKS IN THE HYDRAULIC SYSTEM. SEEK MEDICAL TREATMENT IMMEDIATELY IF INJURED BY HIGH-PRESSURE FLUIDS.**

- **RELIEVE THE HYDRAULIC SYSTEM OF ALL PRESSURE BEFORE ADJUSTING OR SERVICING. SEE THE TRACTOR OPERATOR'S MANUAL FOR PROPER PROCEDURES.**

Bearings & Disc Blades

Check each disc blade to make sure bearings are tight. Grab the outside of the blade and push/pull on the blade. If you can feel the blade move as you push/pull on it you will need to tighten the spindle nut on the hub. Remove the hub cap strap, hub cap and cotter pin. Tighten the nut one notch and check the blade for movement. If the blade is tight replace the cotter pin, hub cap, and strap. Repeat process on all disc blades.

Lubrication

Lubricate unit as outlined in MAINTENANCE section.

Attaching TrackMaster II To Tractor

WARNING

- **CRUSHING CAN CAUSE SERIOUS INJURY OR DEATH. DO NOT STAND BETWEEN THE TOWING VEHICLE AND IMPLEMENT WHEN HITCHING. ALWAYS ENGAGE THE PARKING BRAKE AND STOP THE ENGINE BEFORE INSERTING THE HITCH PINS OR SECURING LATCHES.**

Attach the unit to the tractor as specified in the tractor operator's manual. Use the appropriate size hitch pins and lock in place.

Guide Cone Stabilizer Hydraulic Lift Option Hydraulic Hookup

When connecting the hydraulic lines to a hydraulic source, the lines may be connected into a single selective control valve (SCV) (on back of the tractor). Verify hydraulic operation of guide cone.

WARNING

- **ALWAYS RELIEVE HYDRAULIC SYSTEM PRESSURE BEFORE DISCONNECTING HOSES FROM TRACTOR OR SERVICING HYDRAULIC SYSTEM. SEE TRACTOR OPERATOR'S MANUAL FOR PROPER PROCEDURES.**

NOTE: Refer to SET UP section for purging process.

Transporting

WARNING

- **USE TRANSPORT LIGHTS AS REQUIRED BY ALL LAWS TO ADEQUATELY WARN OPERATORS OF OTHER VEHICLES.**
- **ALWAYS TRAVEL AT A SPEED WHICH PERMITS COMPLETE CONTROL OF TRACTOR AND IMPLEMENT.**

Compliance with all lighting and marking laws is the responsibility of the operator at the time of travel.

See federal regulation 49 CFR 562; available at www.govinfo.gov for US federal law requirements.

See your Unverferth dealer for additional brackets, reflectors, or lights to meet your requirements.

Unhitching From Tractor

WARNING

- **FALLING OR LOWERING EQUIPMENT CAN CAUSE SERIOUS INJURY OR DEATH. KEEP EVERYONE AWAY FROM EQUIPMENT WHEN RAISING OR LOWERING.**

- **HIGH-PRESSURE FLUIDS CAN PENETRATE THE SKIN AND CAUSE SERIOUS INJURY OR DEATH. USE CARDBOARD OR WOOD TO DETECT LEAKS IN THE HYDRAULIC SYSTEM. SEEK MEDICAL TREATMENT IMMEDIATELY IF INJURED BY HIGH-PRESSURE FLUIDS.**

- **RELIEVE THE HYDRAULIC SYSTEM OF ALL PRESSURE BEFORE ADJUSTING OR SERVICING. SEE THE TRACTOR OPERATOR'S MANUAL FOR PROPER PROCEDURES.**

Select a firm, level surface for parking the machine. Lower unit with tractor's 3-point hitch until disc blades contact the ground.

Set parking brake and remove key from ignition before dismounting from tractor.

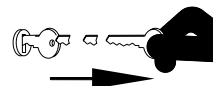

For units with guide cone stabilizer hydraulic lift option, lower implement to ground. Relieve hydraulic pressure (see tractor operating instructions). Disconnect hydraulic lines.

Notes

SECTION IV

Maintenance

Daily Service.....	4-2
Beginning of Day.....	4-2
End of Day.....	4-2
Annual Service.....	4-2
Beginning of Season.....	4-2
End of Season.....	4-2
Lubrication	4-3
Hub Assembly.....	4-3
Complete Torque Chart.....	4-4
Hydraulic Fittings.....	4-5

Daily Service

Beginning of Day

NOTE: Before initial use, ensure all lubrication points have been greased.

Check all U-bolts and bolts for tightness. This is especially important during the first days of operation. See “Torque Chart” in this section.

IMPORTANT

- *Inspect mast pins for any wear or damage. Replace any worn or damaged pins.*

Perform any daily lubrication outlined in “Lubrication” in this section.

IMPORTANT

- *To assure level penetration of disc blades, both tractor tires must be inflated to the same pressure.*

End of Day

Clean off dirt and residue which may have accumulated on implement during operation.

Check implement for damage which could have occurred during operation, and repair.

Annual Service

Beginning of Season

WARNING

- **READ AND UNDERSTAND SAFETY RULES BEFORE OPERATING OR SERVICING THIS MACHINE. REVIEW "SAFETY" SECTION IN THIS MANUAL IF NECESSARY.**

Check all bolts, U-bolts, and wheel bolts for tightness. Refer to “Torque Chart” in this section.

Lubricate implement (see “Lubrication” in this section).

Check air pressure in tires and inflate to correct pressure if necessary (see “Daily Service” in this section).

End of Season

Your implement is an important investment. Spend a little time to protect it from destructive rust and corrosion. You will be repaid in longer service life and better performance.

Perform the following before placing the implement in storage:

1. Remove dirt and residue which could cause rusting.
2. Repaint any chipped or scraped areas.
3. Lubricate implement (see “Lubrication” in this section).
4. Coat all earth moving surfaces with grease or suitable rust preventatives.
5. Inspect for damaged parts. Replace before next season.
6. Store implement inside, away from livestock.
7. Use blocking to keep up off bare ground.
8. Replace all worn, torn or faded decals and reflectors.

Lubrication

IMPORTANT

- *Do not use a high pressure grease gun to lubricate these bearings. Damage to bearing seals could occur.*

Lubricate with an SAE multi-purpose grease. All fittings must be free from dirt and paint to insure entry of lubrication inside bearing.

The disc assembly hub bearing should be cleaned, repacked and adjusted once per season. Use a number 2 wheel bearing grease to repack the bearings and adjust per the Hub Assembly instructions in this section.

Hub Assembly

- 1 Use grease to lubricate the seal lip.
- 2 Place the hub onto the spindle.

NOTE: Make sure the bearing is seated in the cone before the seal is put in place.

- 3 Rotate the hub while doing this so that the seal lip does not fold under as the lip goes on the seal lip of the spindle.
- 4 Be sure the outer cone slides on the spindle and into the cup.
- 5 Assemble the washer and the nut onto the spindle and tighten the nut to 20-25 Ft.-Lbs. Rotate the hub while tightening the nut.
- 6 Back off the nut until it becomes loose.
- 7 While rotating the hub, retighten the nut to remove all clearance.
- 8 Line up the next slot in the nut with the hole in the spindle, insert the cotter pin and bend the cotter pin.
- 9 Install the hub cap.

Complete Torque Chart

Cap screws - Grade 5

NOTE:

- Grade 5 cap screws can be identified by three radial dashes on the head.
- For wheel torque requirements, refer to Wheels and Tires.
- Tighten U-bolts evenly and equally to have the same number of threads exposed on each end.

SIZE	FOOT POUNDS	NEWTON METERS
1/4-20 1/4-28	8-10 9-11	11-13 12-15
5/16-18 5/16-24	15-17 17-19	20-23 23-26
3/8-16 3/8-24	25-28 28-31	34-38 38-42
7/16-14 7/16-20	40-45 45-50	54-61 61-68
1/2-13 1/2-20	62-68 68-75	84-92 92-102
9/16-12 9/16-18	90-98 100-110	122-133 134-148
5/8-11 5/8-18	120-135 124-137	162-183 168-186
3/4-10 3/4-16	200-220 210-230	270-300 285-310
7/8-9 7/8-14	330-350 360-380	425-475 460-515
1-8 1-14	500-525 540-560	675-710 730-760
1 1/8-7 1 1/8-12	600-635 665-700	815-860 920-950
1 1/4-7 1 1/4-12	850-895 940-990	1150-1215 1275-1340
1 3/8-6 1 3/8-12	1125-1175 1280-1335	1525-1590 1735-1810
1 1/2-6 1 1/2-12	1500-1560 1685-1755	2035-2115 2285-2380

IMPORTANT

- Follow these torque recommendations except when specified in text.

Hydraulic Fittings - Torque and Installation

SAE FLARE CONNECTION (J. I. C.)

1. Tighten nut with finger until it bottoms the seat.
2. Using a wrench, rotate nut to tighten. Turn nut 1/3 turn to apply proper torque.

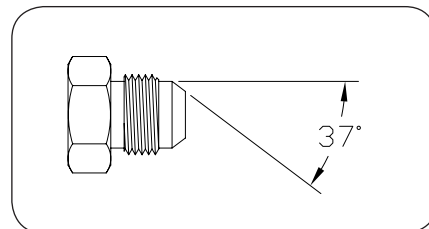

SAE STRAIGHT THREAD O-RING SEAL

1. Insure jam nut and washer are backed up to the back side of smooth portion of elbow adapter.
2. Lubricate O-Ring -- VERY IMPORTANT!
3. Thread into port until washer bottoms onto spot face.
4. Position elbows by backing up adapter.
5. Tighten jam nut.

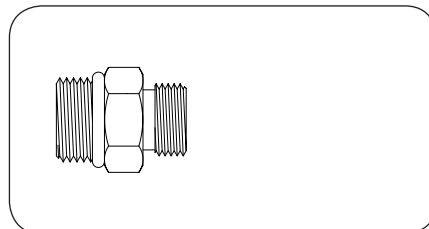

Notes

SECTION V

Parts

Frame Components & Disc Assembly (J80310051BB)	5-2
Disc Assembly Components (J80310012)	5-4
Guide Cone Stabilizer Components (J80310014)	5-6
Guide Cone Stabilizer Hydraulic Lift Option (J80310035)	5-8
LevelPro Option Components (J80310013)	5-10
PackerPro Option Components (J80310042)	5-12
4-Bar Conversion Option Components (J80310037BB)	5-14

TrackMaster II — Parts

Frame Components & Disc Assembly (J80310051BB)

Please visit www.unverferth.com/parts/ for the most current parts listing.

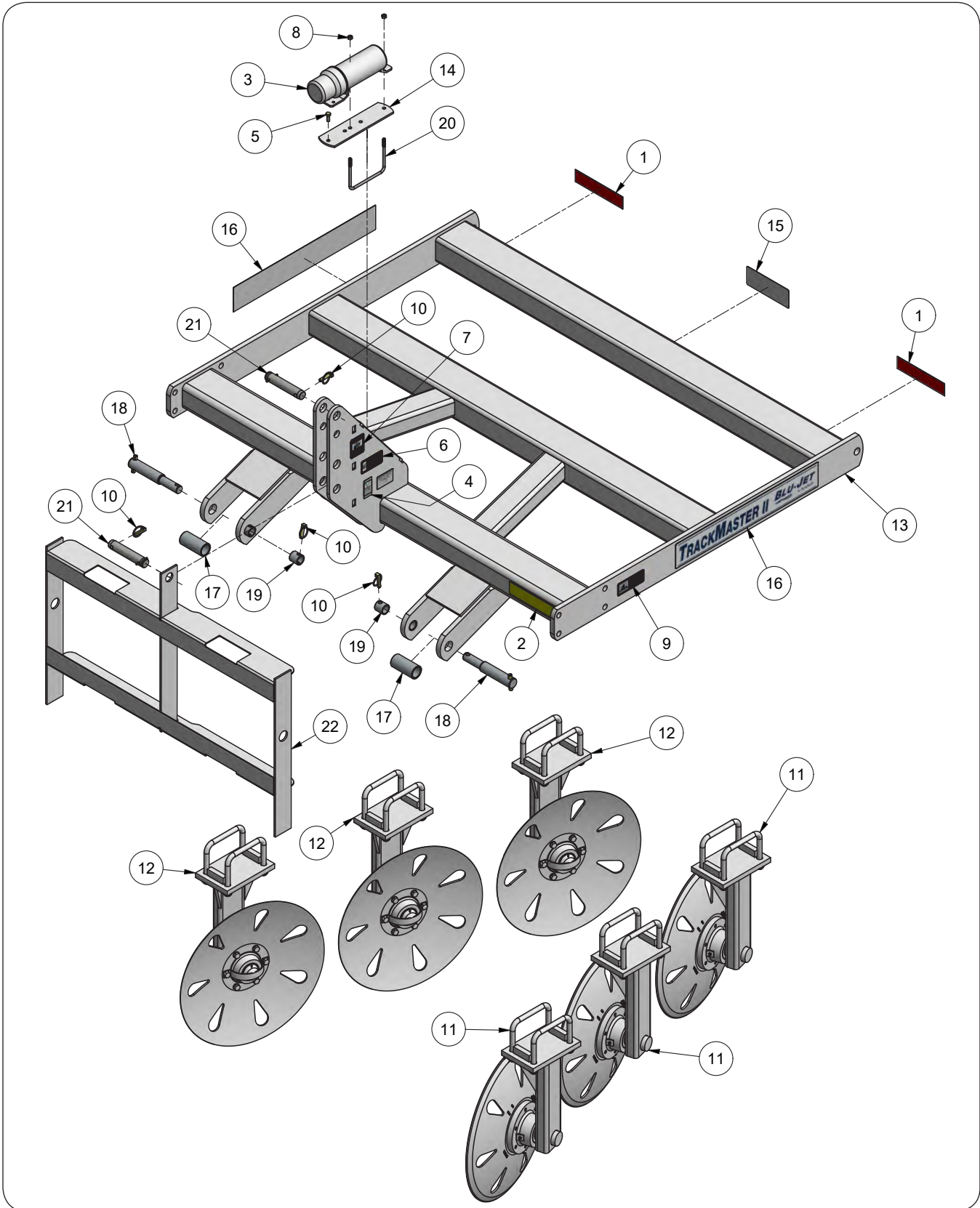

TrackMaster II — Parts

Frame Components & Disc Assembly (J80310051BB)

Please visit www.unverferth.com/parts/ for the most current parts listing.

ITEM	PART NUMBER	DESCRIPTION	QTY	NOTES
	J80310051BB	TrackMaster II Assembly 3-Bar Frame & Disc Assembly	-	Includes Items 1-21
1	9003126	Reflector RED, 2"x9"	2	
2	9003127	Reflector AMBER, 2"x9"	1	
3	900552	Manual Holder	1	
4	91605	Decal, FEMA	1	
5	9390-055	Capscrew, 3/8"-16UNC x 1" G5	1	
6	97961	Decal, WARNING "Read and Understand"	1	
7	97972	Decal, WARNING "Crush Hazard"	1	
8	9928	Lock Nut/Top, 3/8"-16UNC	3	
9	99507	Decal, WARNING "Falling Equipment"	1	
10	9951	Lynch Pin 7/16" Dia. x 1 3/4"	3	
11	JAAM4714	Right-Hand Disc Assembly	3	See "Disc Assembly Components"
12	JAAM4715	Left-Hand Disc Assembly	3	See "Disc Assembly Components"
13	JAM4934BB	Frame 3-Bar Weldment =Blue=	1	
14	JAM7640	Manual Holder Mounting Plate	1	
15	JAP2215	Decal, BLU-JET	1	
16	JAP2579	Decal, TrackMaster II	2	
17	JBM3512	Bushing, 1 1/2" SCH80 x 4	2	
18	JBM3807	Lower Hitch Pin Assembly, CAT2/3 w/Roll Pin	2	
19	JBM3808	Bushing, 1 7/16" OD x 1.170" ID, CAT 2/3	2	
20	JBP3045	U-Bolt, 3/8"-16UNC x 5", 6 7/16" C/C	1	
21	JBP3509	Top Link Pin, 1 1/4" Dia. x 6.53, CAT3 w/Roll Pin	1	
22	79562B	3PT Nose Stand	1	

Disc Assembly Components (J80310012)

Please visit www.unverferth.com/parts/ for the most current parts listing.

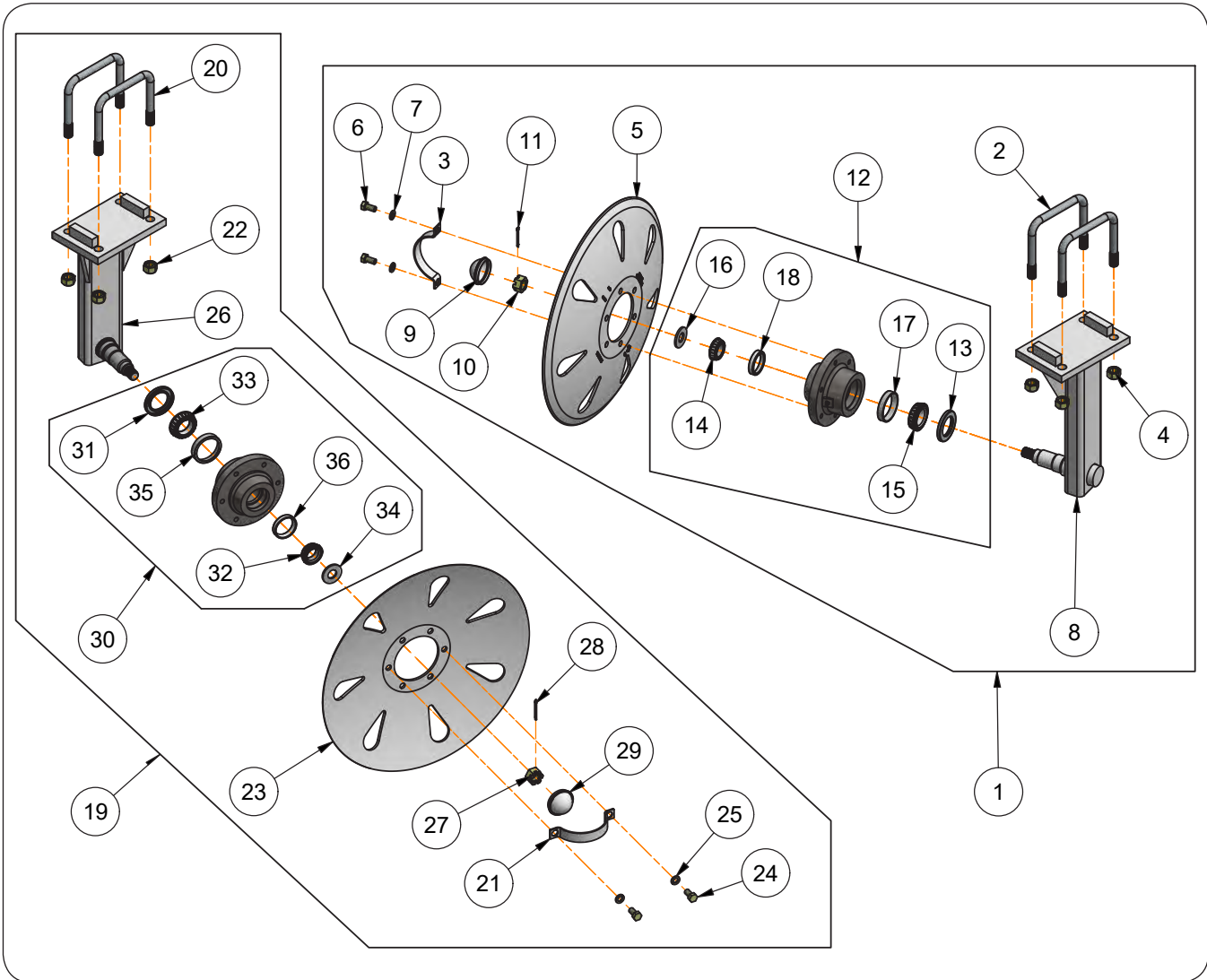

Disc Assembly Components (J80310012)

Please visit www.unverferth.com/parts/ for the most current parts listing.

ITEM	PART NUMBER	DESCRIPTION	QTY	NOTES
	J80310012	Disc Gang (3-Pair) Assembly with Hardware	-	Includes Items 1 & 19
1	JAAM4714	Right-Hand Disc Assembly	3	Includes Items 2-18
2	JBP3208	U-bolt, 3/4"-10UNC x 5 11/16", 6 13/16" C/C	2	
3	JAM4723	Hub Cap Strap	1	
4	9802	Lock Nut/Top 3/4"-10UNC	4	
5	JAP2717	Coulter Blade 22" Dia. Concave Smooth w/Teardrop Cut-Outs	1	
6	9390-323	Capscrew, 1/2"-20UNF x 1" G5	6	
7	9404-025	Lock Washer, 1/2"	6	
8	JEM3391	Disc Spindle Arm Right-Hand Weldment	1	
9	9162	Hub Cap	1	
10	9393-018	Slotted Nut, 7/8"-14UNF	1	
11	9391-036	Cotter Pin, 5/32" Dia. x 1 3/4"	1	
12	9503481B	Hub Assembly, 6-Bolt	1	
13	JAP2145	Seal, Double Lip, 3.000" OD x 1.875" ID	1	
14	9165	Bearing Cone (LM67048)	1	
15	9247	Bearing Cone (LM501349)	1	
16	91146	Spindle Washer, 2" OD x 15/16" ID	1	
17	9349	Bearing Cup (LM501310)	1	
18	9345	Bearing Cup (LM67010)	1	
19	JAAM4715	Left-Hand Disc Assembly	3	Includes Items 20-36
20	JBP3208	U-bolt, 3/4"-10UNC x 5 11/16", 6 13/16" C/C	2	
21	JAM4723	Hub Cap Strap	1	
22	9802	Lock Nut/Top 3/4"-10UNC	4	
23	JAP2717	Coulter Blade 22" Dia. Concave Smooth w/Teardrop Cut-Outs	1	
24	9390-323	Capscrew, 1/2"-20UNF x 1" G5	6	
25	9404-025	Lock Washer, 1/2"	6	
26	JEM3390	Disc Spindle Arm Left-Hand Weldment	1	
27	9393-018	Slotted Nut, 7/8"-14UNF	1	
28	9391-036	Cotter Pin, 5/32" Dia. x 1 3/4"	1	
29	9162	Hub Cap	1	
30	9503481B	Hub Assembly, 6-Bolt	1	
31	JAP2145	Seal, Double Lip, 3.000" OD x 1.875" ID	1	
32	9165	Bearing Cone (LM67048)	1	
33	9247	Bearing Cone (LM501349)	1	
34	91146	Spindle Washer, 2" OD x 15/16" ID	1	
35	9349	Bearing Cup (LM501310)	1	
36	9345	Bearing Cup (LM67010)	1	

Guide Cone Stabilizer Components (J80310014)

Please visit www.unverferth.com/parts/ for the most current parts listing.

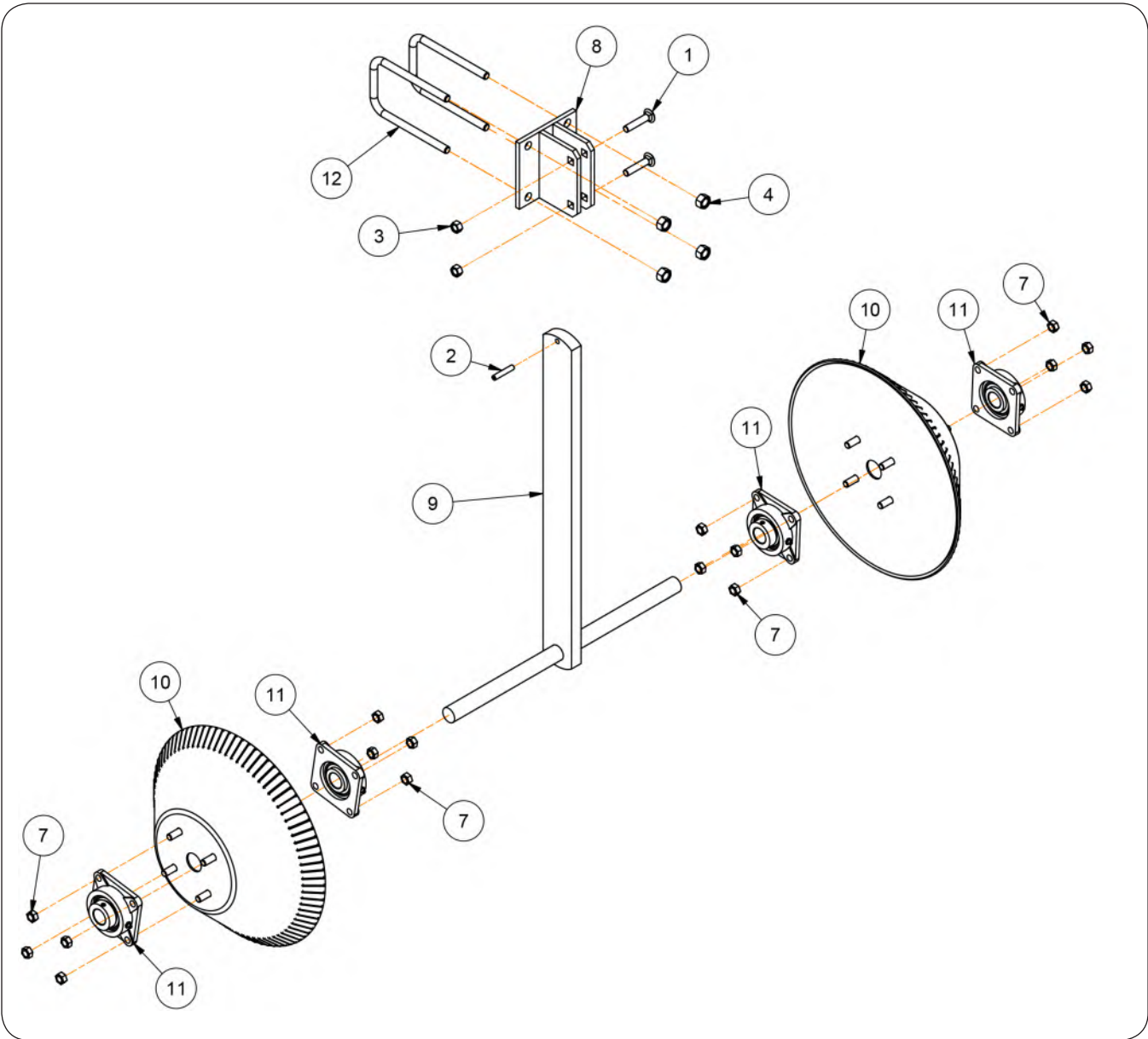

Guide Cone Stabilizer Components (J80310014)

Please visit www.unverferth.com/parts/ for the most current parts listing.

ITEM	PART NUMBER	DESCRIPTION	QTY	NOTES
	J80310014	Guide Cone Stabilizer Assembly	-	Includes Items 1-12
1	9388-108	Carriage Bolt, 1/2"-13UNC x 2 1/2" G5	2	
2	9392-180	Roll Pin, 3/8" Dia. x 2"	1	
3	9800	Lock Nut, 1/2"-13UNC	2	
4	9801	Lock Nut, 5/8-11UNC	4	
7	94981	Lock Nut/Center, 1/2"-13UNC	16	
8	JAM4772	Mounting Bracket Weldment, Flatback/Centered	1	
9	JAM4920	Stabilizer Axle Weldment	1	
10	JAP2740	Individual Guide Cone	2	
11	JAP2757	Flange Bearing 4-Bolt, 1 1/4" Bore	4	
12	JBP3331	U-Bolt, 5/8"-11UNC x 7 1/2", 4 11/16" C/C	2	

Guide Cone Stabilizer Hydraulic Lift Option (J80310035)

Please visit www.unverferth.com/parts/ for the most current parts listing.

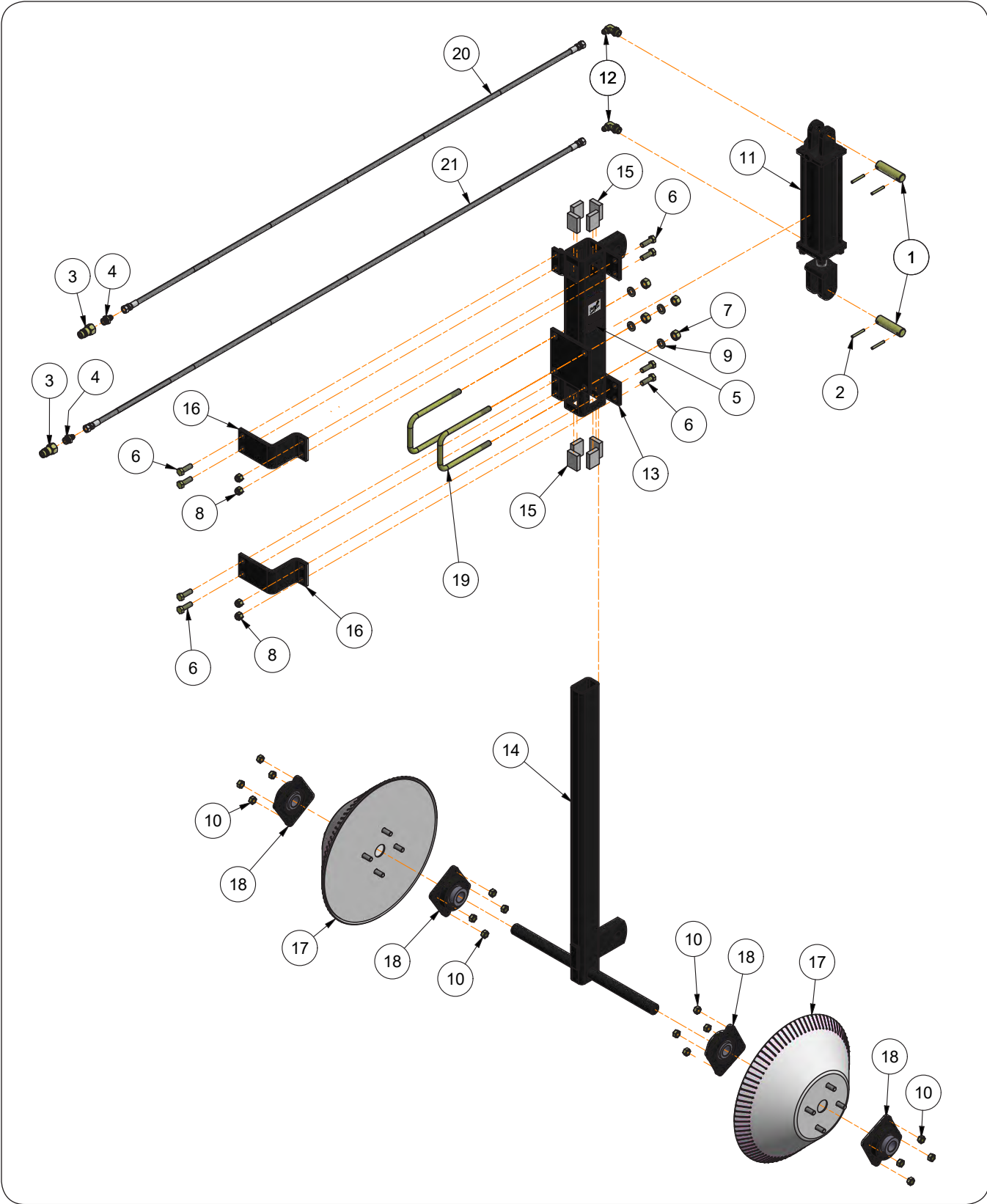

Guide Cone Stabilizer Hydraulic Lift Option (J80310035)

Please visit www.unverferth.com/parts/ for the most current parts listing.

ITEM	PART NUMBER	DESCRIPTION	QTY	NOTES
	J80310035	Guide Cone Stabilizer Hydraulic Lift Assembly	-	Includes Items 1-21
1	85632	Pin, 1" Dia. x 3 3/4"	2	
2	91144-165	Spiral Pin, 1/4" Dia. x 1 7/8"	4	
3	91383	Male Tip Coupling, 3/4"-16	2	
4	92927	Adapter, 9/16"-18 JIC Male x 3/4"-16 O-Ring Male	2	
5	93551	Decal, WARNING "Hydraulic Pressure"	1	
3	9390-101	Capscrew, 1/2"-13UNC x 1 1/2" G5	8	
7	9394-014	Hex Nut, 5/8-11UNC	4	
8	9398-016	Elastic Lock Nut, 1/2"-13UNC	8	
9	9404-029	Lock Washer, 5/8"	4	
10	94981	Lock Nut/Center, 1/2"-13UNC	16	
11	98241	Hydraulic Cylinder 3" x 10"	1	
	9003772	Seal Kit	-	
12	9874	90° Elbow, 9/16"-18 JIC Male x 3/4"-16 O-Ring Male	2	
13	JAM3203	Hydraulic Lift Mounting Assembly	1	
14	JAM3204	Stabilizer Hydraulic Lift Axle Weldment	1	
15	JAM3205	Plastic Slide Bearing 1 1/2" x 2"	8	
16	JAM3271	Clamp	2	
17	JAP2740	Individual Guide Cone	2	
18	JAP2757	Flange Bearing 4-Bolt, 1 1/4" Bore	4	
19	JBP3331	U-Bolt, 5/8"-11UNC x 7 1/2", 4 11/16" C/C	2	
20	JDP5043	Hydraulic Hose 1/4" x 72", 9/16"-18 JIC Female x 9/16"-18 JIC Female	1	
21	JDP5073	Hydraulic Hose 1/4" x 78", 9/16"-18 JIC Female x 9/16"-18 JIC Female	1	

TrackMaster II — Parts

LevelPro Option Components (J80310013)

Please visit www.unverferth.com/parts/ for the most current parts listing.

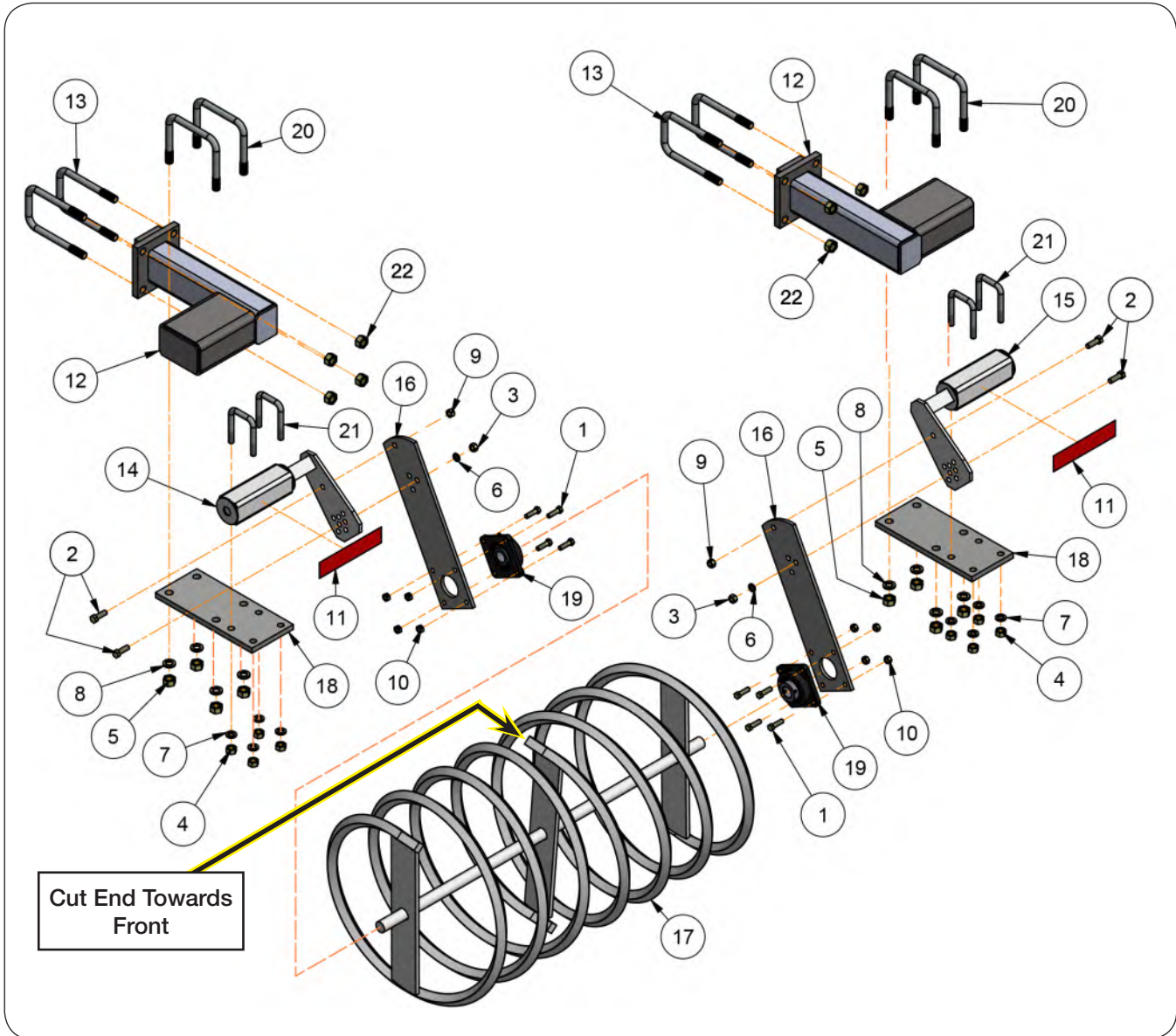

LevelPro Option Components (J80310013)

Please visit www.unverferth.com/parts/ for the most current parts listing.

ITEM	PART NUMBER	DESCRIPTION	QTY	NOTES
	J80310013	LevelPro Assembly	-	Includes Items 1-21
1	9390-080	Capscrew, 7/16"-14UNC x 1 1/2" G5	8	
2	9390-101	Capscrew, 1/2"-13UNC x 1 1/2" G5	4	
3	9394-010	Hex Nut, 1/2"-13UNC	2	
4	9394-014	Hex Nut, 5/8"-11UNC	8	
5	9394-016	Hex Nut, 3/4"-10UNC	8	
6	9404-025	Lock Washer, 1/2"	2	
7	9404-029	Lock Washer, 5/8"	8	
8	9404-033	Lock Washer, 3/4"	8	
9	9800	Lock Nut/Top, 1/2"-13UNC	2	
10	94980	Lock Nut/Center, 7/16"-14UNC	8	
11	9003126	Decal, Reflector RED 2"x9"	2	
12	JAM2394	Offset Stagger Bracket Weldment	2	
13	JBP3047	U-Bolt, 3/4"-10UNC x 7 3/4", 4 13/16" C/C	4	
14	JAM4921	Torsion Spring Weldment Left-Hand	1	
15	JAM4922	Torsion Spring Weldment Right-Hand	1	
16	JAM4923	Leveler Mounting Plate	2	
17	JAM4924	Leveler Coil Assembly	1	
18	JAM7637	Mounting Plate	2	
19	JAP2757	Flange Bearing 4-Bolt	2	
20	JBP3208	U-Bolt, 3/4"-10UNC x 5 11/16", 6 13/16" C/C	4	
21	JBP3300	U-Bolt, 5/8"-11UNC x 4", 3 3/16" C/C	4	
22	9802	Lock Nut, 3/4"-10UNC	8	

PackerPro Option Components (J80310042)

Please visit www.unverferth.com/parts/ for the most current parts listing.

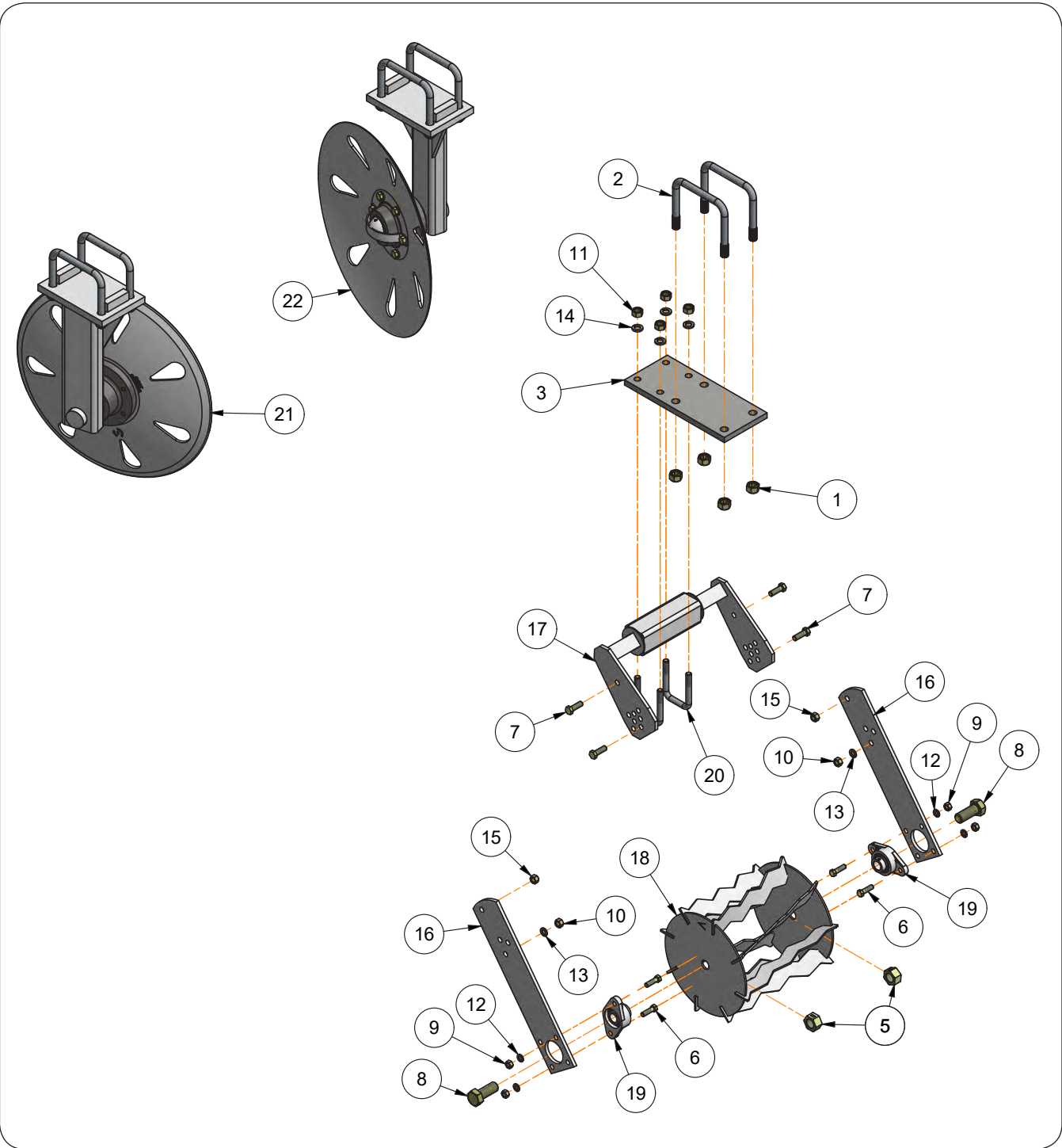

PackerPro Option Components (J80310042)

Please visit www.unverferth.com/parts/ for the most current parts listing.

ITEM	PART NUMBER	DESCRIPTION	QTY	NOTES
	J80310042	PackerPro Assembly	-	Includes Items 1-22
1	9802	Lock Nut/Top, 3/4"-10UNC	4	
2	JBP3208	U-Bolt, 3/4"-10UNC x 5 11/16", 6 13/16" C/C	2	
3	JAM7637	Basket Mounting Plate	1	
4	J70210641	Torsion Basket Bundle (Short)	1	Includes Items 5-20
5	92199	Lock Nut/Center, 1"-8UNC	2	
6	9390-080	Capscrew, 7/16"-14UNC x 1 1/2" G5	4	
7	9390-101	Capscrew, 1/2"-13UNC x 1 1/2" G5	4	
8	9390-185	Capscrew, 1"-8UNC x 2 1/2" G5	2	
9	9394-008	Hex Nut, 7/16"-14UNC	4	
10	9394-010	Hex Nut, 1/2"-13UNC	2	
11	9394-014	Hex Nut, 5/8"-11UNC	4	
12	9404-023	Lock Washer, 7/16"	4	
13	9404-025	Lock Washer, 1/2"	2	
14	9404-029	Lock Washer, 5/8"	4	
15	9800	Lock Nut/Top, 1/2"-13UNC	2	
16	JAM2269	Strip-Till Basket Mount (Short)	2	
17	JAM7568	Torsion Spring Basket	1	
18	JAM7615	Basket Weldment, 12 3/4"	1	
19	JAP2144	Flange Bearing 2-Bolt	2	
20	JBP3300	U-Bolt, 5/8"-11UNC	2	
21	JAAM4714	Right-Hand Disc Assembly	1	See "Disc Assembly Components"
22	JAAM4715	Left-Hand Disc Assembly	1	See "Disc Assembly Components"

4-Bar Conversion Option Components (J80310037BB)

Please visit www.unverferth.com/parts/ for the most current parts listing.

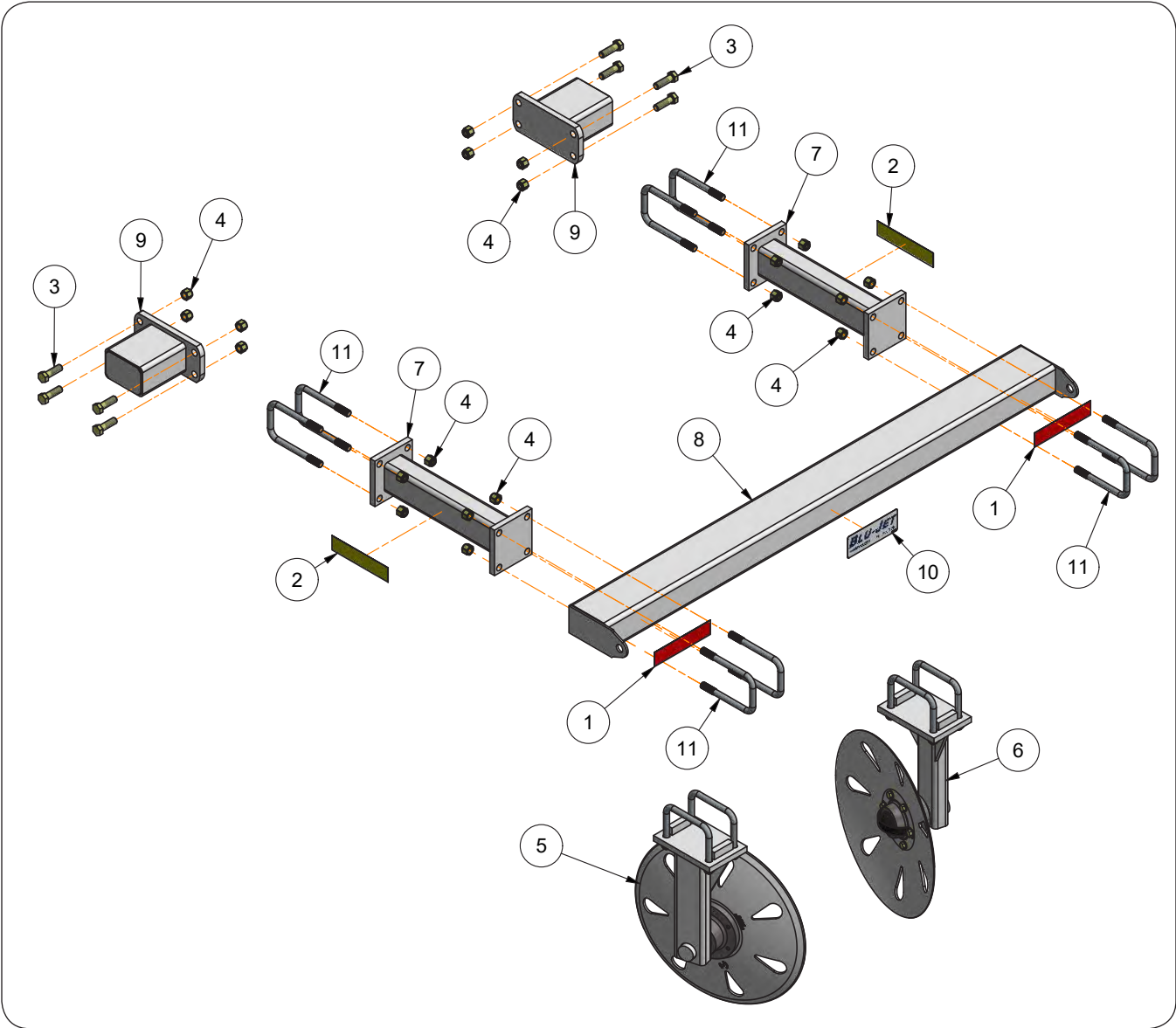

4-Bar Conversion Option Components (J80310037BB)

Please visit www.unverferth.com/parts/ for the most current parts listing.

ITEM	PART NUMBER	DESCRIPTION	QTY	NOTES
	J80310037BB	4-Bar Conversion Option	-	Includes Items 1-11
1	9003126	Decal, Reflector RED 2"x9"	2	
2	9003127	Decal, Reflector AMBER 2"x9"	2	
3	9390-147	Capscrew, 3/4"-10UNC x 2 1/2" G5	8	
4	9398-021	Elastic Lock Nut, 3/4"-10UNC	24	
5	JAAM4714	Right-Hand Disc Assembly	1	See "Disc Assembly Components"
6	JAAM4715	Left-Hand Disc Assembly	1	See "Disc Assembly Components"
7	JAM3400BB	Extension Bracket 20" Weldment	2	
8	JAM4927BB	Bolt-On Bar Weldment	1	
9	JAM4935BB	Stub Extension Bracket Weldment	2	
10	JAP2215	Decal, BLU-JET 3"x8"	1	
11	JBP3047	U-Bolt, 3/4"-10UNC x 7 3/4", 4 13/16" C/C	8	

